

● Assembly Tools

Assembly Tools	6
Pulse Wrenches Shut-off type	11
Geared Pulse Wrenches Shut-off type	13
Pulse Wrenches	14
Impact Wrenches	17
Screwdrivers	22
Open-end Wrenches / Ratchet Wrenches	24
Accessories	25



Selection Guide

TIGHTENING TORQUE (N.m)

This table shows the recommended tightening torque for common bolt size M2 to M48.

Bolt Size	Bolt Grade							Bolt Size	Bolt Grade					
	3.0	4.6	4.8	5.8	8.8	10.9	12.9		mm	4.6	4.8	5.8	8.8	10.9
M2	0.10	0.13	0.17	0.22	0.35	0.49	0.58	M18	103	121	172	275	386	463
M3	0.35	0.46	0.61	0.77	1.20	1.70	2.10	M20	144	170	240	385	541	649
M4	0.81	1.10	1.40	1.80	2.90	4.00	4.90	M22	194	230	324	518	728	874
M5	0.60	2.20	2.95	3.60	5.70	8.10	9.70	M24	249	295	416	665	935	1120
M6	2.80	3.70	4.90	6.10	9.80	14.0	17.0	M27	360	435	600	961	1350	1620
M8		8.9	10.5	15	24	33	40	M30	492	590	819	1310	1840	2210
M10		17	21	29	47	65	79	M36	855	1030	1420	2280	3210	3850
M12		30	36	51	81	114	136	M42	1360		2270	3640	5110	6140
M14		48	58	80	128	181	217	M45	1690		2820	4510	6340	7610
M16		74	88	123	197	277	333	M48	2040		3400	5450	7660	9190

according to ISO898/1

RECOMMENDED TORQUE RANGE

The torque requirement is one of the major factors to be considered when selecting fastening tools. The following graphic presentation shows the recommended torque range of our assembly tools. This is to be used for guidance only as final torque may vary depending on the type and size of the fastener, the joint rate, air pressure, etc.

Optimum performance is achieved at the mid range of the tool's torque capability.

PULSE WRENCHES SHUT-OFF TYPE

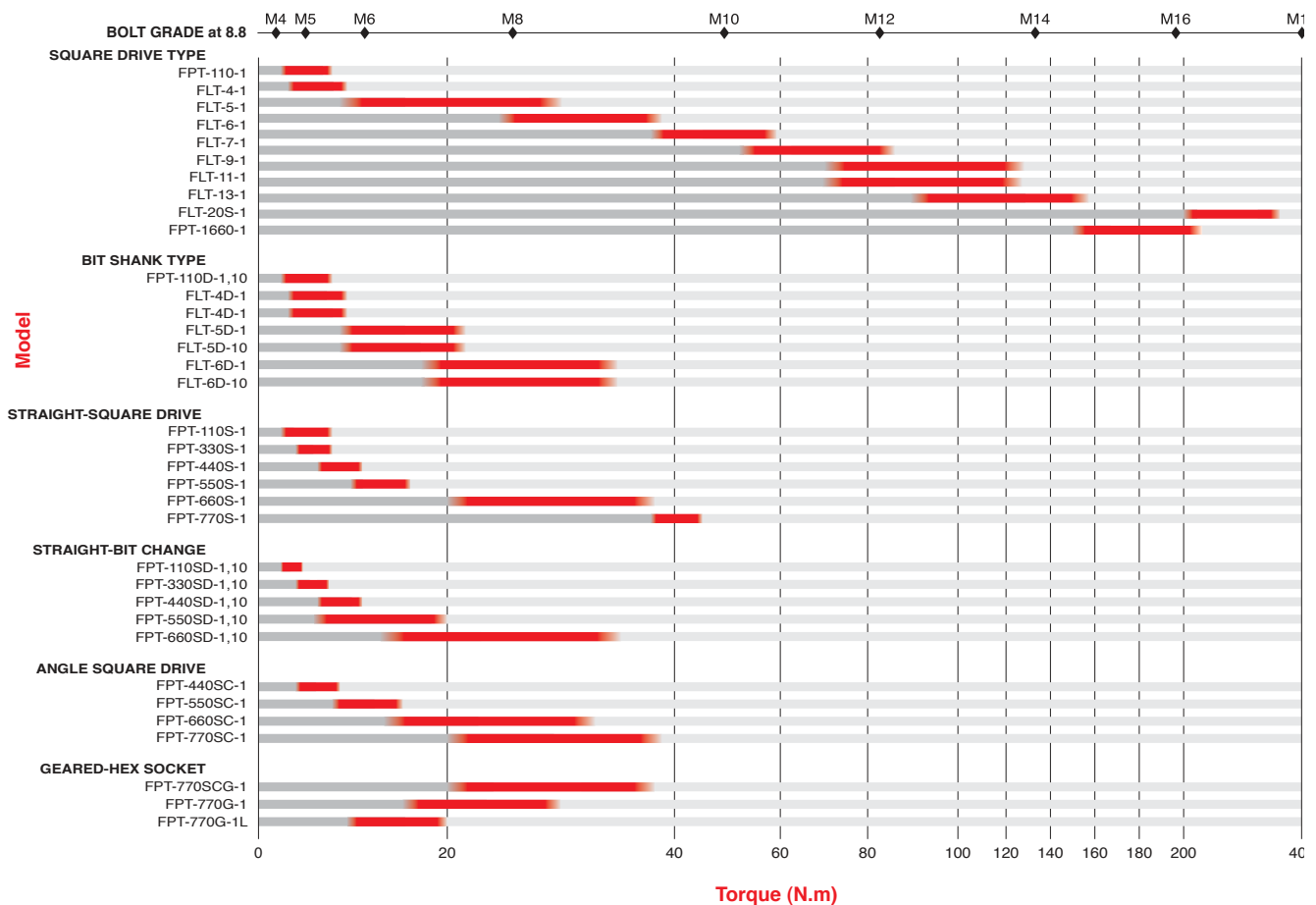

PULSE WRENCHES

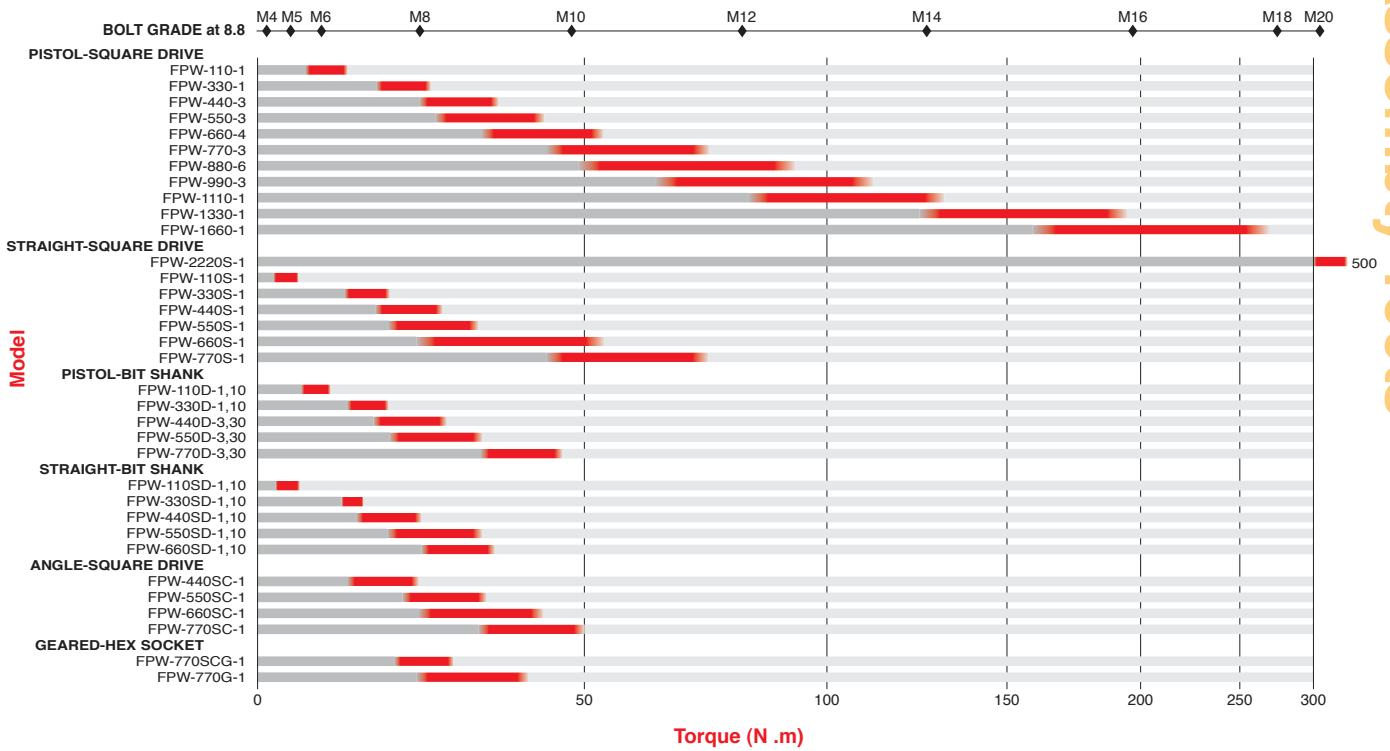

IMPACT WRENCHES

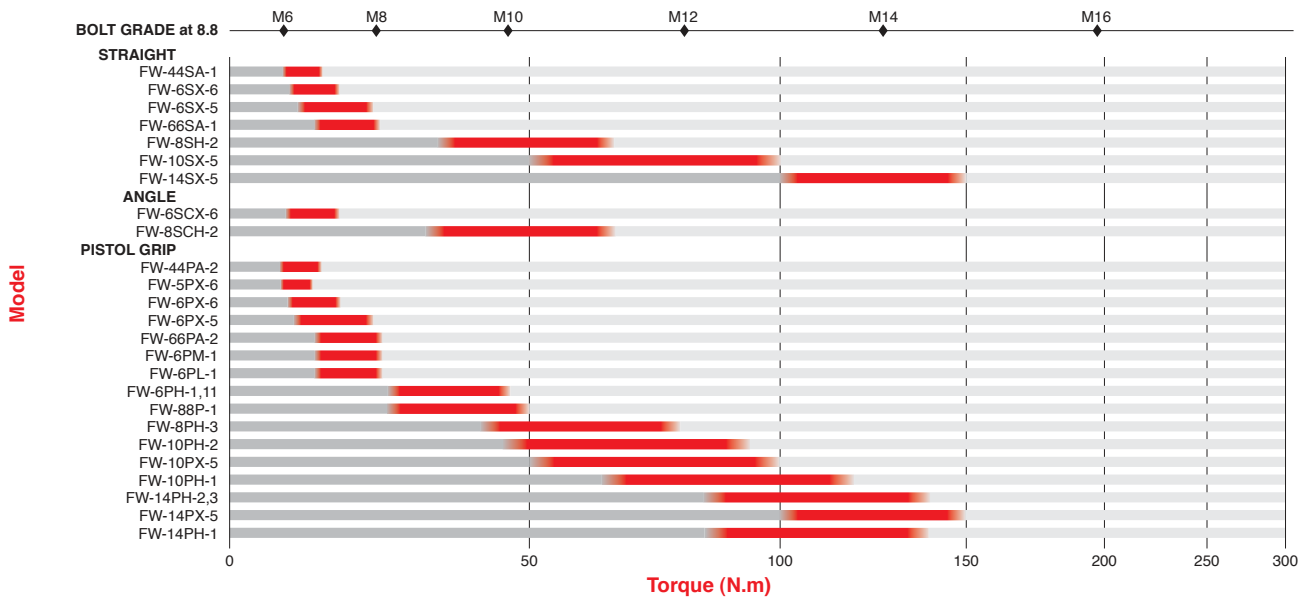

Torque range should be used for guidance only as final torque may vary depending on the type and size of fastener, the joint rate, air pressure etc. Optimum performance is achieved at the mid range of the tool's torque capability.

Selection Guide

IMPACT WRENCHES

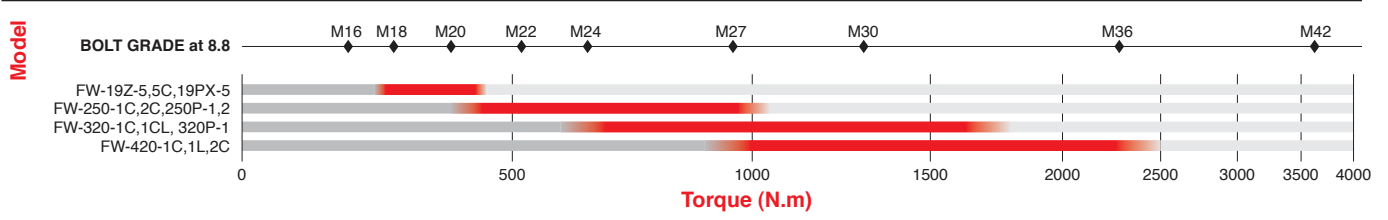

LARGE IMPACT WRENCHES

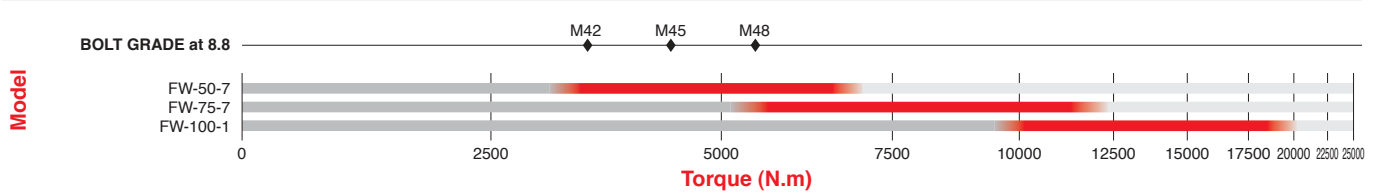

SCREW DRIVERS

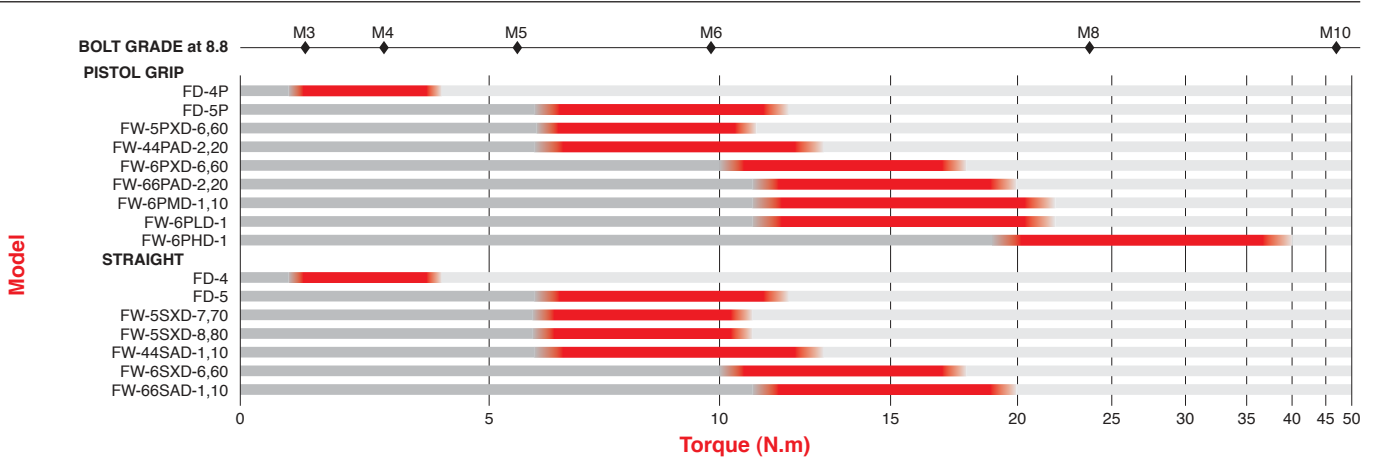

Torque range should be used for guidance only as final torque may vary depending on the type and size of the fastener, the joint rate, air pressure, etc. Optimum performance is achieved at the mid range of the tool's torque capability.

Oil Filler

The Fuji oil filler is the ideal, and indispensable, equipment required for maintenance and repair of pulse wrenches. By connecting a conventional air supply to the handle valve, the oil filler makes re-filling the pulse unit assembly quick and easy.

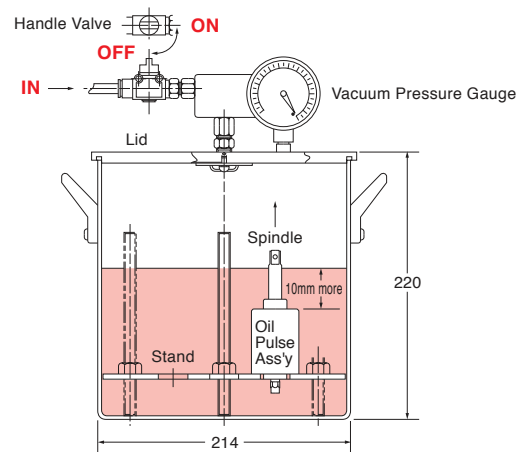

1 EXHAUST WITH A MUFFLER

Our original built-in, swivel type, exhaust muffler is designed to reduce the noise level of the tool. The operator can also select a suitable direction of the exhaust air to minimise the risk of blowing any dust or debris in to the local work environment.

ALL WRENCHES EXCEPT FW-6PL, 6PLD, 5SXD-8, 80, FD-4, 5, 4P, 5P



REAR EXHAUST MUFFLER



FRONT EXHAUST
FPW-2220S, FW-19Z, 250~420,
FW-50, 75, 100

2 TWO STAGE / SQUEEZING TYPE THROTTLE VALVE MECHANISM

The two stage / squeeze type throttle enables the operator to start the tool slowly and increase to full speed to aid location of the fastening at the start of the cycle.

TWO STAGE TYPE : FPT, FPW, FW-6PM, 44P~88P

SQUEEZING TYPE : FPT-*S, FPW-*S, FW-44S~66S, FOW, FRW



3 REVERSE VALVE LEVER

All models feature a reversible motor. The operator can easily and quickly select the direction of rotation simply by turning or sliding the reverse actuator.

ALL WRENCHES EXCEPT FOW, FRW

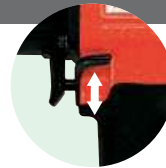

FPW pistol, straight

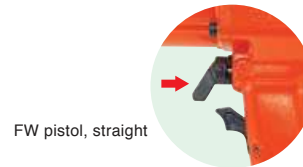

FW pistol, straight

4 AIR REGULATOR

To accommodate torque adjustment, the built in air regulator is used to regulate the air flow.

FW-6SX, 8SH, 10SX, 14SX, 6SCX, 8SCH, 50~100

FW-6PX, 10PX, 14PX, 19Z, 420 SERIES



5 SQUARE DRIVE ANVIL

Two types of square drive anvils are available. As our standard for overseas, the models larger than 25.4 mm (1 inch) square drive are supplied with P anvil (Pin hole retainer type) and the models smaller than 19 mm (3/4 inch) square drive are supplied with BF anvil (Flat button retainer type). Small models can be supplied with P anvil on your request.

ALL WRENCHES WITH SQUARE DRIVE ANVIL

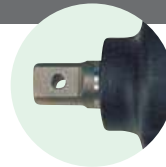

P ANVIL



BF ANVIL

6 BIT SHANK TYPE ANVIL FOR SCREW DRIVERS

Two types of quick-change bit shank type anvils are available. Both are for 6.35 mm (1/4 inch) hex driver bit, but divided into two model groups according to the bit neck size.

ALL SCREW DRIVERS

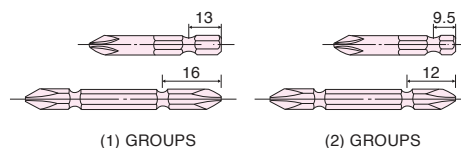

(1) GROUPS

(2) GROUPS



7 CLUTCH MECHANISM-IMPACT WRENCHES AND DRIVERS

1) DOUBLE CLUTCH TYPE

The impact force is balanced with less torque reaction due to two impacts made per revolution.

The double clutch type impact wrenches and drivers benefit from less vibration and longer service life than conventional single clutch models.

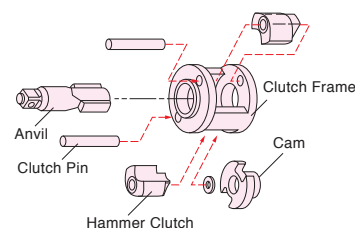

Features

2) SINGLE CLUTCH TYPE

The impact force is harder and torque/weight ratio is better than the double clutch type. Single clutch type models are suitable for hard "pull-up" fastening operations for maintenance & service applications.

FW-6PX, 6SX-5, 10PX, 10SX-5, 14PX, 14SX-5, 19Z, 19PX-5, 5C

3) 2-JAW ONE-DOG CLUTCH TYPE

The Fuji 2-Jaw clutch impact wrenches generate very high torque/weight. These types of tool are most suited for tightening prevailing torque bolts and for removing corroded fasteners.

FW-250, 320, 420 SERIES

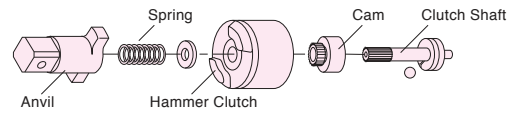
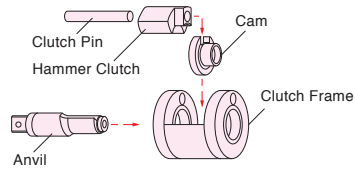

8 HANDLE PROTECTOR

Ergonomically designed handle protectors provide reduced vibration, increased operator comfort and insulate the hand from the cold temperature generated by compressed air.

PISTOL GRIP MODELS : FPT, FPW, FW-6PM, 44P~88P



9 DUAL CHAMBER MOTOR

All Fuji pulse wrench models (FPT & FPW) and the new series of impact wrenches (FW-44~88) are built with a 9-blade, dual chamber motor. This motor is designed to provide high torque at low speed, giving the best characteristics for fast reliable and accurate tightening.

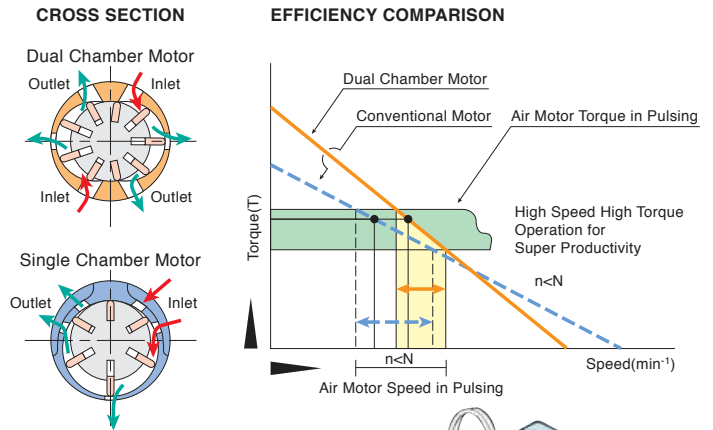

10 2-BLADE PULSE UNIT

As the pulsing cycle is very short, there is almost no torque reaction in the handle grip (low motor torque only is felt by the operator). Unlike an impact wrench, the pulse tool has no "metal to metal" contact and consequently the pulse wrenches provide softer and stable "impulsing". The benefits from this are less vibration, lower noise levels and longer service life when compared with conventional impact wrenches.

All pulse wrenches models (FPT & FPW series) utilise the Fuji patented 2-blade pulse unit combined with the dual chamber motor. This combination provides 50% higher power to weight ratio than comparable fastening tools.

For productivity, this design reaches torque faster, which is excellent for soft joint or prevailing torque applications with reduced noise and vibration levels.

FPT, FPW SERIES

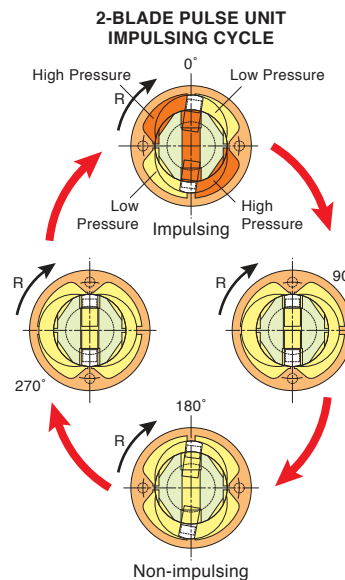
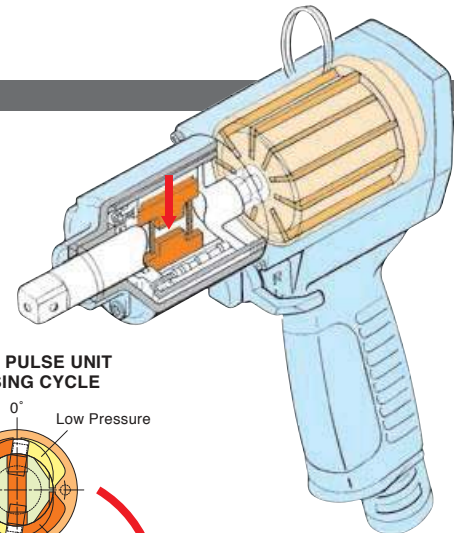

Pulse Wrenches Shut-off Type

"FPT and FLT Series" are provided with Fuji patented original shut-off control mechanism having a dual chamber motor and 2-blade pulsing mechanism. It is designed for giving high torque at low speed, which gives the best characteristics for fast, reliable and accurate tightening. FPT and FLT Series contribute to high productivity, quality improvement, working environment improvement, and operator fatigue minimization in various industries.

SQUARE DRIVE TYPE

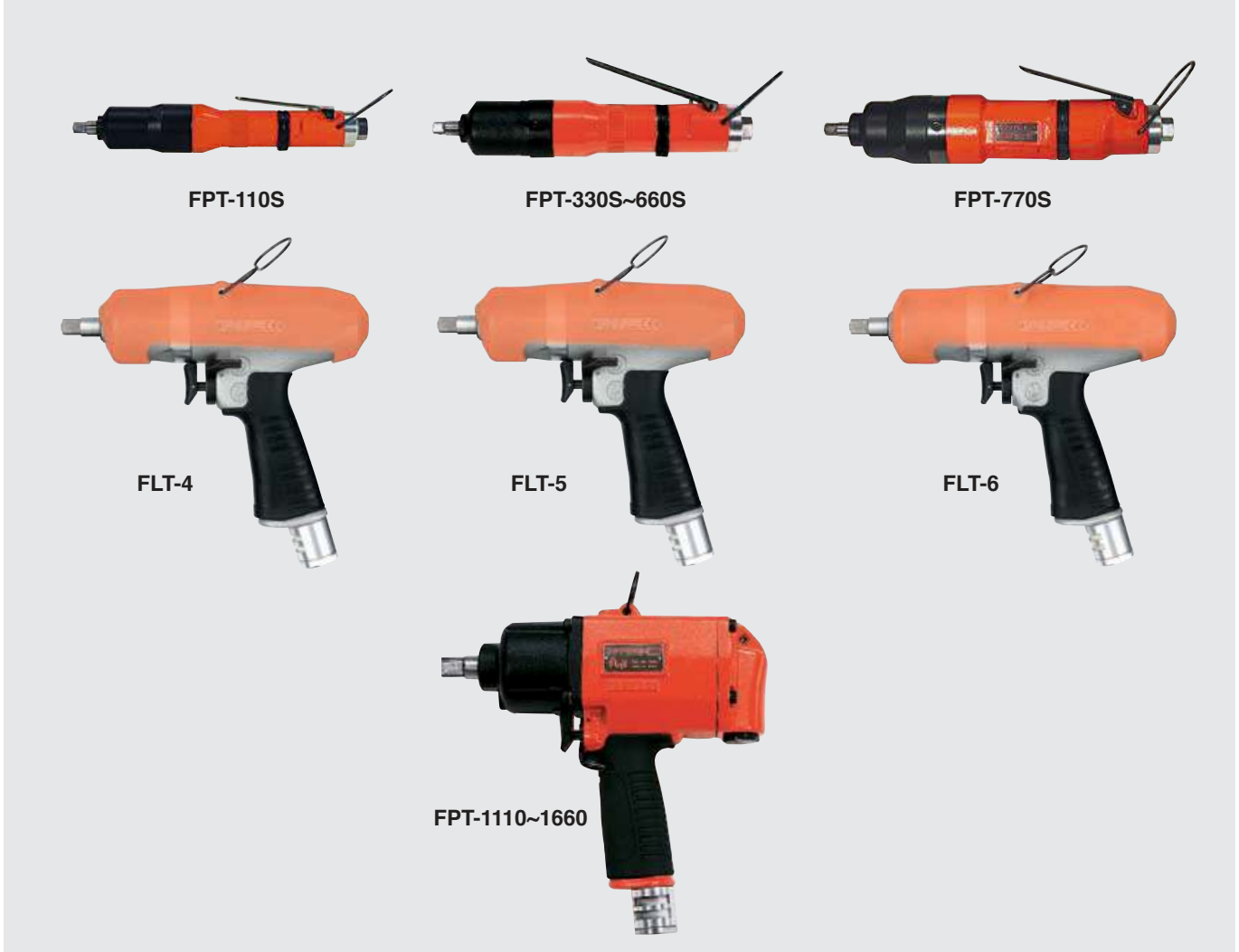

Models to be operated at air pressure 0.5MPa to 0.6MPa (5.0 to 6.3 bar)

Model	Bolt Size	Recommended Torque Range			Free Speed	Square Drive Size		Overall Length		Weight (without socket)		Air Consumption (at Load)	
		mm	N · m	kgf · m		ft · lb	mm	in	mm	in	kg	lb	m ³ /min
Straight Models													
FPT-110S-1	M4~M5	4~7	0.4~0.7	3.0~5.2	4,500	9.5	3/8	236.5	9 5/16	0.85	1.9	0.20	7.1
FPT-330S-1	M5~M6	6~10	0.6~1.0	4.4~7.4	4,400	9.5	3/8	249	9 13/16	1.1	2.4	0.35	12.3
FPT-440S-1	M5~M6	8~13	0.8~1.3	5.9~9.6	5,000	9.5	3/8	250	9 27/32	1.1	2.4	0.35	12.3
FPT-550S-1	M6~M8	12~20	1.2~2.0	8.9~14.8	5,000	9.5	3/8	250	9 27/32	1.1	2.4	0.35	12.3
FPT-660S-1	M6~M8	20~30	2.0~3.1	14.8~22.1	5,000	9.5	3/8	262	10 21/64	1.1	2.4	0.50	17.6
FPT-770S-1	M8~M10	30~45	3.1~4.6	22.1~33.2	5,500	9.5	3/8	273.5	10 49/64	1.6	3.5	0.45	15.9
Pistol Grip Models													
FPT-110-1	M5~M6	4~7	0.4~0.7	3.0~5.2	6,000	9.5	3/8	194.5	7 21/32	0.95	2.1	0.20	7.1
FLT-4-1	M5~M6	5~12	0.5~1.2	3.6~8.8	6,200	9.5	3/8	181	7 1/8	0.97	2.1	0.40	14.1
FLT-5-1	M6~M8	11~24	1.1~2.4	8.1~17.7	6,500	9.5	3/8	181	7 1/8	0.97	2.1	0.45	15.8
FLT-6-1	M8~M10	22~35	2.2~3.5	16.2~25.8	6,300	9.5	3/8	192	7 19/32	1.00	2.2	0.55	19.4
FLT-7-1	M8~M10	30~60	3.0~6.1	22.1~44.2	6,100	9.5	3/8	189.5	7 29/64	1.10	2.4	0.60	21.1
FLT-9-1	M10	50~85	5.1~8.6	36.8~62.6	5,300	12.7	1/2	209	8 15/64	1.60	3.5	0.68	24.0
FLT-11-1	M10~M12	70~130	7.1~13.2	51.6~95.8	5,000	12.7	1/2	217.5	8 9/16	1.85	4.1	0.80	28.2
FLT-13-1	M12~M14	90~160	9.1~16.3	66.3~118	3,400	12.7	1/2	227.5	8 61/64	2.10	4.6	0.85	30.0
FLT-20S-1	M18~M20	200~400	20.4~40.8	147.5~295	2,500	19.0	3/4	405	15 3/32	8.80	19.4	1.3	45.8
FPT-1660-1	M16~M18	150~210	15.3~21.4	110.6~154.9	2,800	19.0	3/4	266	10 31/64	4.4	9.7	1.2	42.4

*Use all above models at 0.5-0.63 MPa (5.0 to 6.3 bar) air pressure but FPT-110 series at 0.4-0.63 MPa (4.0-6.3 bar) air pressure.

*Performance figures are at 0.63 MPa (6.3 bar) air pressure. *Air Inlet Thread Size: BSP or NPT 1/4", (FPT-1660) BSP or NPT 3/8".

*Air Hose Size: (FPT-110S, 330S, 440S, 550S, FLT-4-1, 5-1) 6.3mm (1/4"). (660S, 770S, 1660-1, FLT-6-1, 7-1, 9-1, 11-1, 13-1) 9.5mm (3/8"), (FLT-20S-1) 12.7mm (1/2").

Pulse Wrenches Shut-off Type

BIT SHANK TYPE



Models to be operated at air pressure 0.5MPa to 0.63MPa (5.0 to 6.3 bar)

Model	Bolt Size mm	Recommended Torque Range			Free Speed min ⁻¹	Bit Shank Size		Overall Length		Weight (without socket)		Air Consumption (at Load)	
		N · m	kgf · m	ft · lb		mm	in	mm	in	kg	lb	m ³ /min	ft ³ /min
Straight Models													
FPT-110SD-1(10)	M4~M5	4~7	0.4~0.7	3.0~5.2	4,500	6.35	1/4	240	9 29/64	0.85	1.9	0.20	7.1
FPT-330SD-1(10)	M5~M6	6~10	0.6~1.0	4.4~7.4	4,400	6.35	1/4	249	9 13/16	1.1	2.4	0.35	12.3
FPT-440SD-1(10)	M5~M6	8~13	0.8~1.3	5.9~9.6	5,000	6.35	1/4	251	9 57/64	1.1	2.4	0.35	12.3
FPT-550SD-1(10)	M6~M8	12~20	1.2~2.0	8.9~14.8	5,000	6.35	1/4	251	9 57/64	1.1	2.4	0.35	12.3
FPT-660SD-1(10)	M6~M8	15~28	1.5~2.9	11.1~20.7	5,000	6.35	1/4	262	10 21/64	1.1	2.4	0.50	17.6
Pistol Grip Models													
FPT-110D-1(10)	M5~M6	4~7	0.4~0.7	3.0~5.2	6,000	6.35	1/4	197.5	7 25/32	0.95	2.1	0.20	7.1
FPT-330-1	M5~M6	6~11	0.6~1.1	4.4~8.1	6,000	9.5	3/8	198	7 51/64	1.2	2.6	0.39	13.8
FPT-440D-1(10)	M6	10~16	1.0~1.6	7.4~11.8	6,700	6.35	1/4	193	7 39/64	1.2	2.6	0.35	12.3
FLT-4D-1	M6	14~20	1.4~2.0	10.3~14.7	6,700	6.35	1/4	140	5 3/64	0.79	1.7	0.36	12.7
FLT-4D-10	M6	14~20	1.4~2.0	10.3~14.7	6,700	6.35	1/4	140	5 3/64	0.79	1.7	0.36	12.7
FLT-5D-1	M6~M8	18~32	1.7~3.2	13.2~23.6	6,300	6.35	1/4	140	5 3/64	0.79	1.7	0.40	14.1
FLT-5D-10	M6~M8	18~32	1.7~3.2	13.2~23.6	6,300	6.35	1/4	140	5 3/64	0.79	1.7	0.40	14.1
FLT-6D-1	M8	25~42	2.5~4.2	18.4~30.9	6,700	6.35	1/4	152	5 63/64	0.83	1.8	0.42	14.8
FLT-6D-10	M8	25~42	2.5~4.2	18.4~30.0	6,700	6.3	1/4	152	5 63/64	0.83	1.8	0.42	14.8

*Use all above models at 0.5-0.63 MPa (5.0 to 6.3 bar) air pressure but FPT-110 series at 0.4-0.63 MPa (4.0-6.3 bar) air pressure.

*Performance figures are at 0.63 MPa (6.3 bar) air pressure. *Air Inlet Thread Size: or NPT 1/4".

*Air Hose Size: (FPT-110SD, 330SD, 440SD, 550SD, 110D, 330D, FLT-4D-1, 4D-10, 5D-1, 5D-10) 6.3mm (1/4"). (FPT660SD, FLT-6D-1, FLD-6D-10) 9.5mm (3/8").

SQUARE DRIVE TYPE



Models to be operated at air pressure 0.5MPa to 0.63MPa (5.0 to 6.3 bar)

Model	Bolt Size mm	Recommended Torque Range			Free Speed min ⁻¹	Square Drive Size		Overall Length		Weight (without socket)		Air Consumption (at Load)	
		N · m	kgf · m	ft · lb		mm	in	mm	in	kg	lb	m ³ /min	ft ³ /min
Angle Head Models													
FPT-440SC-1	M5~M6	6~11	0.6~1.1	4.4~8.1	4,500	9.5	3/8	280	11 1/32	1.46	3.2	0.35	12.4
FPT-550SC-1	M6	10~17	1.0~1.7	7.4~12.5	4,800	9.5	3/8	280	11 1/32	1.46	3.2	0.35	12.4
FPT-660SC-1	M6~M8	15~25	1.5~2.6	11.1~18.4	4,700	9.5	3/8	292	11 1/2	1.54	3.4	0.5	17.7
FPT-770SC-1	M8	20~35	2.0~3.6	14.8~25.8	5,500	9.5	3/8	306	12 3/64	2.3	5.1	0.45	15.9

*Air Inlet Thread Size: BSP or NPT 1/4". *Air Hose Size: 6.3mm (1/4"). (660SC, 770SC) 9.5mm (3/8").

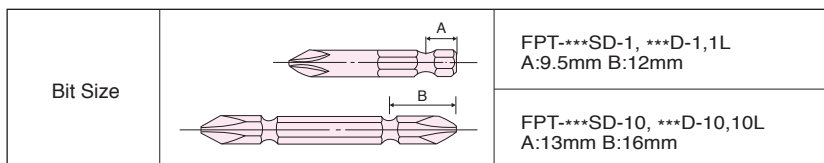

Geared Pulse Wrenches Shut-off Type

The Fuji Geared Pulse Wrenches Shut-Off type provides high power in combination with low noise and vibration through the Dual Chamber Air Motor & Gear-drive angle head.

The ergonomic design reduces the reaction forces experienced by the operator throughout the torque range.



FPT-770SCG-1

Models to be operated at air pressure 0.5MPa to 0.63MPa (5.0 to 6.3 bar)

Model	Bolt Size	Recommended Torque Range			Free Speed	Socket Hex Size		Overall Length		Weight		Air Consumption (at Load)		Air Hose Size	
		mm	N · m	kgf · m		ft · lb	mm	in	mm	in	kg	lb	m ³ /min	ft ³ /min	mm
FPT-770SCG-1	M6	17~24	1.7~2.4	12.5~17.7	6,400	12	15/32	378	14 7/8	2.6	5.7	0.45	15.9	9.5	3/8

*Air Inlet Thread Size: BSP or NPT 1/4".

Pulse Wrenches

Featured with dual chamber air motor, FPW and FL series pulse wrenches are designed to generate higher torque and yet reducing vibration, torque reaction and noise levels. Combined with 2-blade impulsing mechanism, 9-blade dual chamber motor creates about 50% higher power-to-weight ratio than our former series of the same physical size. The reduction of vibration and torque reaction helps reduce operator fatigue and other problems associated with repeated vibration or impact motion.

SQUARE DRIVE TYPE



Model	Bolt Size	Recommended Torque Range			Free Speed	Square Drive Size		Overall Length (without socket)		Weight (without socket)		Air Consumption (at Load)		Air Hose Size	
		mm	N · m	kgf · m		ft · lb	min ⁻¹	mm	in	mm	in	kg	lb	m ³ /min	ft ³ /min
Pistol Grip Models															
FPW-110-1	M4~M5	7.5~13 (2~7.5)	0.8~1.3 (0.2~0.8)	5.5~9.6 (1.4~5.5)	4,500	9.5	3/8	143	5 41/64	0.75	1.7	0.20	7.1	6.3	1/4
FL-4-1	M6	16~24	1.6~2.4	11.8~17.7	6,700	9.5	3/8	139.5	5 31/64	0.79	1.7	0.36	12.7	6.3	1/4
FL-5-1	M6~M8	20~40	2.0~4.0	14.7~29.5	6,300	9.5	3/8	139.5	5 31/64	0.79	1.7	0.40	14.1	6.3	1/4
FL-6-1	M8	28~56	2.8~5.6	20.6~41.3	6,700	9.5	3/8	151.5	5 31/32	0.83	1.8	0.42	14.8	9.5	3/8
FL-7-1	M8~M10	34~60	3.4~6.1	25.0~44.2	6,100	9.5	3/8	155	6 7/64	1.02	2.2	0.60	21.1	9.5	3/8
FL-9-1	M10	52~96	5.3~9.7	38.3~70.8	5,000	12.7	1/2	173	6 13/16	1.45	3.2	0.65	22.9	9.5	3/8
FL-11-1	M10~M12	80~136	8.1~13.8	59.0~100.3	5,000	12.7	1/2	184	7 15/64	1.80	4.0	0.80	28.2	9.5	3/8
FL-13-1	M12~M14	120~172	12.2~17.5	88.5~126.8	3,800	12.7	1/2	192	7 9/16	2.10	4.6	0.85	30.0	9.5	3/8
FPW-1660-1	M16~M18	160~270	16.3~27.5	118~199.1	3,000	19.0	3/4	243	9 37/64	3.80	8.4	1.20	42.4	9.5	3/8

*Air Inlet Thread Size: BSP or NPT 1/4", (FPW-1660)PT or NPT 3/8".

*Figures in () can be obtained at the position of "L" mark on the regulator knob, but for another, at "H" mark.

BIT SHANK TYPE

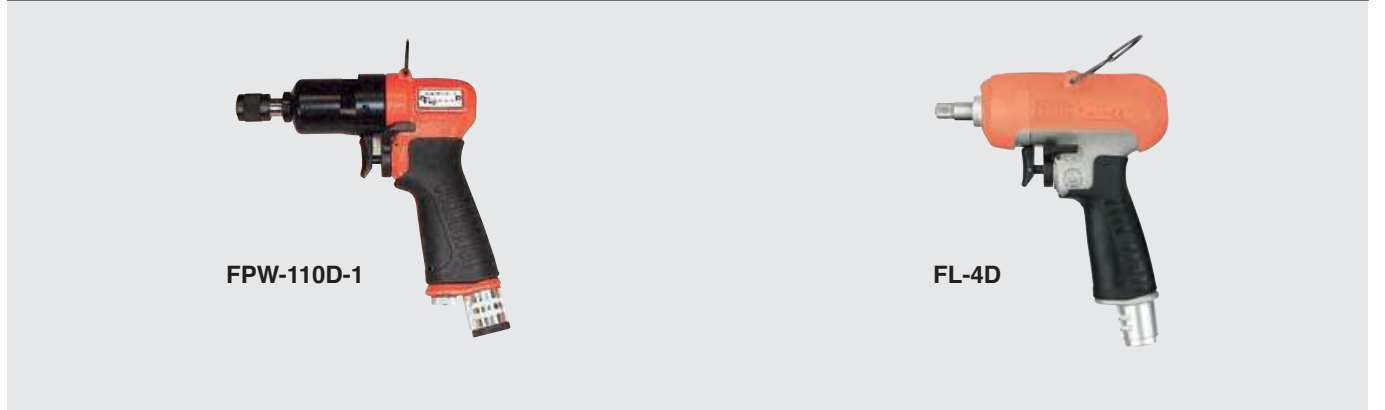

Model	Bolt Size	Recommended Torque Range			Free Speed	Bit Shank Size		Overall Length (without socket)		Weight (without socket)		Air Consumption (at Load)		Air Hose Size	
		mm	N · m	kgf · m		ft · lb	min ⁻¹	mm	in	mm	in	kg	lb	m ³ /min	ft ³ /min
Pistol Grip Models															
FPW-110D-1	M4~M5	7~11 (2~7)	0.7~1.1 (0.2~0.7)	5.2~8.1 (1.4~5.1)	4,500	6.35	1/4	149	5 7/8	0.76	1.7	0.20	7.1	6.3	1/4
FPW-110D-10	M4~M5	7~11	0.7~1.1	5.2~8.1	4,500	6.35	1/4	149	5 7/8	0.76	1.7	0.20	7.1	6.3	1/4
FL-4D-1	M6	14~20	1.4~2.0	10.3~14.7	6,700	6.35	1/4	140	5 3/64	0.79	1.7	0.36	12.7	6.3	1/4
FL-4D-10	M6	14~20	1.4~2.0	10.3~14.7	6,700	6.35	1/4	140	5 3/64	0.79	1.7	0.36	12.7	6.3	1/4
FL-5D-1	M6~M8	18~32	1.8~3.2	13.2~23.6	6,300	6.35	1/4	140	5 3/64	0.79	1.7	0.40	14.1	6.3	1/4
FL-5D-10	M6~M8	18~32	1.8~3.2	13.2~23.6	6,300	6.35	1/4	140	5 3/64	0.79	1.7	0.40	14.1	6.3	1/4
FL-6D-1	M8	25~42	2.5~4.2	18.4~30.9	6,700	6.35	1/4	152	5 63/64	0.83	1.8	0.42	14.8	6.3	1/4
FL-6D-10	M8	25~42	2.5~4.2	18.4~30.9	6,700	6.35	1/4	152	5 63/64	0.83	1.8	0.42	14.8	6.3	1/4

*Air Inlet Thread Size: BSP or NPT 1/4".

*Figures in () can be obtained at the position of "L" mark on the regulator knob, but for another, at "H" mark.

SQUARE DRIVE TYPE



FPW-110S~660S



FPW-770S-1



FPW-2220S-1

Model	Bolt Size	Recommended Torque Range			Free Speed	Square Drive Size		Overall Length (without socket)		Weight (without socket)		Air Consumption (at Load)		Air Hose Size	
		mm	N · m	kgf · m		ft · lb	mm	in	mm	in	kg	lb	m ³ /min	ft ³ /min	mm
Straight Models															
FPW-110S-1	M4	2~7.5	0.2~0.8	1.5~5.5	3,200	9.5	3/8	218	8 19/32	0.65	1.4	0.20	7.1	6.3	1/4
FPW-330S-1	M5	13~22	1.3~2.2	9.6~16.2	4,400	9.5	3/8	226	8 57/64	0.87	1.9	0.30	10.6	6.3	1/4
FPW-440S-1	M4~M6	20~34	2.0~3.5	14.8~25.1	5,500	9.5	3/8	226	8 57/64	0.87	1.9	0.35	12.4	6.3	1/4
FPW-550S-1	M6~M8	27~44	2.8~4.5	19.9~32.5	5,700	9.5	3/8	226	8 57/64	0.87	1.9	0.37	13.1	6.3	1/4
FPW-660S-1	M6~M8	34~54	3.5~5.5	25.1~39.8	5,800	9.5	3/8	238	9 3/8	0.95	2.1	0.50	17.7	9.5	3/8
FPW-770S-1	M8	44~76	4.5~7.8	32.5~56.1	6,300	9.5	3/8	240	9 7/16	1.25	2.7	0.50	17.7	9.5	3/8
FPW-2220S-1	M18~M20	300~500	30.6~51.0	221.3~368.8	2,500	19.0	3/4	350	10 13/16	7.00	15.4	1.30	45.9	12.7	1/2

*Air Inlet Thread Size: BSP or NPT 1/4", (FPW-2220S) BSP or NPT 1/2".

BIT SHANK TYPE



FPW-110SD



FPW-330SD~660SD

Model	Bolt Size	Recommended Torque Range			Free Speed	Bit Shank Size		Overall Length (without socket)		Weight (without socket)		Air Consumption (at Load)		Air Hose Size	
		mm	N · m	kgf · m		ft · lb	mm	in	mm	in	kg	lb	m ³ /min	ft ³ /min	mm
Straight Models															
FPW-110SD-1	M4	2~7	0.2~0.7	1.5~5.2	3,200	6.35	1/4	224	8 53/64	0.65	1.4	0.20	7.1	6.3	1/4
FPW-110SD-10	M4	2~7	0.2~0.7	1.5~5.2	3,200	6.35	1/4	224	8 53/64	0.65	1.4	0.20	7.1	6.3	1/4
FPW-330SD-1	M5	12~17	1.2~1.7	8.9~12.5	4,400	6.35	1/4	226	8 57/64	0.88	1.9	0.30	10.6	6.3	1/4
FPW-330SD-10	M5	12~17	1.2~1.7	8.9~12.5	4,400	6.35	1/4	226	8 57/64	0.88	1.9	0.30	10.6	6.3	1/4
FPW-440SD-1	M4~M6	15~25	1.5~2.6	11.1~18.4	5,500	6.35	1/4	226	8 57/64	0.88	1.9	0.35	12.4	6.3	1/4
FPW-440SD-10	M4~M6	15~25	1.5~2.6	11.1~18.4	5,500	6.35	1/4	226	8 57/64	0.88	1.9	0.35	12.4	6.3	1/4
FPW-550SD-1	M4~M6	20~34	2.0~3.5	14.8~25.1	5,700	6.35	1/4	226	8 57/64	0.88	1.9	0.37	13.1	6.3	1/4
FPW-550SD-10	M4~M6	20~34	2.0~3.5	14.8~25.1	5,700	6.35	1/4	226	8 57/64	0.88	1.9	0.37	13.1	6.3	1/4
FPW-660SD-1	M6~M8	25~37	2.6~3.8	18.4~27.3	5,800	6.35	1/4	238	9 3/8	0.95	2.1	0.50	17.7	9.5	3/8
FPW-660SD-10	M6~M8	25~37	2.6~3.8	18.4~27.3	5,800	6.35	1/4	238	9 3/8	0.95	2.1	0.50	17.7	9.5	3/8

*Air Inlet Thread Size: BSP or NPT 1/4".

Bit Size		FPW-***SD-1, FPW-***D-1,2,3,4 A:9.5mm B:12mm
		FPW-***SD-10, FPW-***D-10,20,30,40 A:13mm B:16mm

Pulse Wrenches

SQUARE DRIVE TYPE



FPW-440SC~660SC



FPW-770SC-1

Model	Bolt Size	Recommended Torque Range			Free Speed	Square Drive Size		Overall Length (without socket)		Weight (without socket)		Air Consumption (at Load)		Air Hose Size	
		mm	N · m	kgf · m		ft · lb	mm	in	mm	in	kg	lb	m ³ /min	ft ³ /min	mm
Angle Head Models															
FPW-440SC-1	M4~M6	13~24	1.3~2.4	9.6~17.7	5,000	9.5	3/8	255	10 3/64	1.28	2.8	0.39	13.8	6.3	1/4
FPW-550SC-1	M6~M8	22~35	2.2~3.6	16.2~25.8	5,500	9.5	3/8	255	10 3/64	1.29	2.8	0.39	13.8	6.3	1/4
FPW-660SC-1	M6~M8	25~43	2.6~4.4	18.4~31.7	5,500	9.5	3/8	267	10 33/64	1.40	3.1	0.48	16.9	9.5	3/8
FPW-770SC-1	M8	33~50	3.4~5.1	24.3~36.9	6,300	9.5	3/8	271	10 43/64	1.70	3.7	0.50	17.7	9.5	3/8

*Air Inlet Thread Size: BSP or NPT 1/4".

Geared Pulse Wrenches

The Fuji Geared Pulse Wrenches Shut-Off type provides high power in combination with low noise and vibration through the Dual Chamber Air Motor & Gear-drive angle head.

The ergonomic design reduces the reaction forces experienced by the operator throughout the torque range.



FPW-770SCG-1

Model	Bolt Size	Recommended Torque Range			Free Speed	Socket Hex Size		Overall Length		Weight		Air Consumption (at Load)		Air Hose Size	
		mm	N · m	kgf · m		ft · lb	mm	in	mm	in	kg	lb	m ³ /min	ft ³ /min	mm
FPW-770SCG-1	M4~M6	21~30	2.1~3.1	15.5~22.1	7,000	12	15/32	343	13 33/64	2.0	4.4	0.50	17.7	9.5	3/8

*Air Inlet Thread Size: BSP or NPT 1/4".

'Dual Chamber Motor' Impact Wrenches

Fuji Impact Wrenches FW-44~88 have 9-blade dual chamber motor and double clutch type impact mechanism. They are designed for giving high torque at low speed, which give the best characteristics for fast reliable and accurate tightening. These models are provided with two types of lubricant in clutch part, FW-44PA~66PA and FW-44SA~66SA series are with oil (Oil Bath type) which features long service life and FW-44P~88P and FW-44S~66S are with conventional grease. Both series are suitable for self tapping type soft joint.

Pistol Grip Models

9.5mm(3/8")~12.7mm(1/2")



FW-44PA~66PA



FW-88P-1

Model	Bolt Size	Recommended Torque Range			Max. Torque	Free Speed	Square Drive Size		Overall Length (without socket)		Weight (without socket)		Air Consumption (at Load)		Air Hose Size	
		mm	N · m	kgf · m			ft · lb	N · m	min ⁻¹	mm	in	mm	in	kg	lb	m ³ /min
•FW-44PA-2	M5	8~16	0.8~1.6	5.9~11.8	20	6,500	9.5	3/8	131	5 5/32	0.78	1.7	0.60	21.2	6.3	1/4
•FW-66PA-2	M6	14~26	1.4~2.7	10.3~19.2	32	5,000	9.5	3/8	137	5 25/64	0.88	1.9	0.48	16.9	6.3	1/4
FW-88P-1	M8	27~50	2.8~5.1	19.9~36.9	70	5,300	12.7	1/2	163	6 27/64	1.40	3.1	0.64	22.5	9.5	3/8

*Marked • are oil bath types. *All Models are double clutch types.
*Air Inlet Thread Size: BSP or NPT 1/4".

Straight Model



FW-44SA~66SA

Model	Bolt Size	Recommended Torque Range			Max. Torque	Free Speed	Square Drive Size		Overall Length (without socket)		Weight (without socket)		Air Consumption (at Load)		Air Hose Size	
		mm	N · m	kgf · m			ft · lb	N · m	min ⁻¹	mm	in	mm	in	kg	lb	m ³ /min
•FW-44SA-1	M5	8~16	0.8~1.6	5.9~11.8	20	5,700	9.5	3/8	207	8 5/32	0.66	1.4	0.35	12.4	6.3	1/4
•FW-66SA-1	M6	14~26	1.4~2.7	10.3~19.2	32	5,000	9.5	3/8	212	8 11/32	0.78	1.7	0.37	13.1	6.3	1/4

*Marked • are oil bath types. *All Models are double clutch types.
*Air Inlet Thread Size: BSP or NPT 1/4".

Impact Wrenches

Fuji Impact Wrenches are suitable for various fastening and unfastening operations. The combination of high torque and fast run down minimise operator fatigue.



Model	Bolt Size	Recommended Torque Range			Max. Torque	Free Speed	Square Drive Size		Overall Length (without socket)		Weight (without socket)		Air Consumption (at Load)		Air Hose Size	
		mm	N · m	kgf · m			ft · lb	N · m	min ⁻¹	mm	in	mm	in	kg	lb	m ³ /min
•FW-5PX-6	M5	8~13	0.8~1.3	5.9~9.6	18	12,000	9.5	3/8	150	5 29/32	0.80	1.8	0.20	7.1	6.3	1/4
•FW-6PM-1	M6	14~26	1.4~2.7	10.3~19.2	32	8,500	9.5	3/8	140	5 33/64	0.92	2.0	0.53	18.7	9.5	3/8
•FW-6PL-1	M6	14~26	1.4~2.7	10.3~19.2	32	10,000	9.5	3/8	175	6 57/64	0.90	2.0	0.20	7.1	9.5	3/8
FW-6PX-5	M6	11~23	1.1~2.3	8.1~17.0	30	10,000	9.5	3/8	156	6 9/64	1.20	2.6	0.28	9.9	9.5	3/8
•FW-6PX-6	M6	10~18	1.0~1.8	7.4~13.3	25	10,000	9.5	3/8	156	6 9/64	1.20	2.6	0.28	9.9	9.5	3/8
•FW-6PH-1	M8	27~40	2.8~4.1	19.9~29.5	60	9,000	9.5	3/8	147	5 25/32	1.35	3.0	0.35	12.4	9.5	3/8
•FW-6PH-11	M8	27~40	2.8~4.1	19.9~29.5	60	9,000	12.7	1/2	152	6	1.40	3.1	0.35	12.4	9.5	3/8
•FW-8PH-3	M10	42~80	4.3~8.2	31.0~59.0	130	7,500	12.7	1/2	162	6 3/8	1.50	3.3	0.40	14.1	9.5	3/8
FW-10PX-5	M10	50~100	5.1~10.2	36.9~73.8	150	8,000	12.7	1/2	182	7 11/64	2.30	5.0	0.40	14.1	9.5	3/8
•FW-10PH-1	M10	63~120	6.4~12.2	46.5~88.5	160	7,500	12.7	1/2	179	7 3/64	2.00	4.4	0.45	15.8	9.5	3/8
•FW-10PH-2	M10	47~93	4.8~9.5	34.7~68.6	113	7,500	12.7	1/2	179	7 3/64	2.00	4.4	0.45	15.8	9.5	3/8
FW-14PX-5	M14	100~150	10.2~15.3	73.8~110.6	190	6,500	12.7	1/2	197	7 3/4	3.00	6.6	0.40	14.1	9.5	3/8
•FW-14PH-1	M14	85~140	8.7~14.3	62.7~103.3	180	7,500	12.7	1/2	202	7 15/16	2.56	5.7	0.60	21.2	9.5	3/8
•FW-14PH-2	M14	85~140	8.7~14.3	62.7~103.3	180	7,500	12.7	1/2	202	7 15/16	2.56	5.7	0.60	21.2	9.5	3/8
•FW-14PH-3	M14	85~140	8.7~14.3	62.7~103.3	180	7,500	15.9	5/8	202	7 15/16	2.56	5.7	0.60	21.2	9.5	3/8

*Marked • are double clutch types. Others are single clutch types.

*Air Inlet Thread Size: BSP or NPT 1/4".

Small Size Straight Models

9.5mm (3/8")~12.7mm (1/2")



FW-6SX-5,6



FW-8SH-2



FW-10SX-5



FW-14SX-5

Model	Bolt Size	Recommended Torque Range			Max. Torque	Free Speed	Square Drive Size		Overall Length (without socket)		Weight (without socket)		Air Consumption (at Load)		Air Hose Size	
		mm	N · m	kgf · m			ft · lb	N · m	min ⁻¹	mm	in	mm	in	kg	lb	m ³ /min
FW-6SX-5	M6	11~23	1.1~2.3	8.1~17.0	30	10,000	9.5	3/8	223	8 25/32	1.10	2.4	0.30	10.6	9.5	3/8
•FW-6SX-6	M6	10~18	1.0~1.8	7.4~13.3	25	10,000	9.5	3/8	223	8 25/32	1.10	2.4	0.30	10.6	9.5	3/8
•FW-8SH-2	M10	35~67	3.6~6.8	25.8~49.4	93	8,000	12.7	1/2	306	12 3/64	1.70	3.7	0.40	14.1	9.5	3/8
FW-10SX-5	M10	50~100	5.1~10.2	36.9~73.8	150	8,000	12.7	1/2	317	12 31/64	2.20	4.8	0.40	14.1	9.5	3/8
FW-14SX-5	M14	100~150	10.2~15.3	73.8~110.6	190	6,500	12.7	1/2	356	14 1/64	3.00	6.6	0.50	17.7	9.5	3/8

*Marked • are double clutch types. Others are single clutch types.

*Air Inlet Thread Size: BSP or NPT 1/4".

Angle Head Models



FW-6SCX-6



FW-8SCH-2

Model	Bolt Size	Recommended Torque Range			Max. Torque	Free Speed	Square Drive Size		Overall Length (without socket)		Weight (without socket)		Air Consumption (at Load)		Air Hose Size	
		mm	N · m	kgf · m			ft · lb	N · m	min ⁻¹	mm	in	mm	in	kg	lb	m ³ /min
•FW-6SCX-6	M6	9~18	0.9~1.8	6.6~13.3	20	8,000	9.5	3/8	261	10 9/32	1.60	3.5	0.30	10.5	9.5	3/8
•FW-8SCH-2	M10	33~67	3.4~6.8	24.3~49.4	87	7,500	12.7	1/2	347	13 21/32	2.70	5.9	0.40	14.1	9.5	3/8

*Marked • are double clutch types.

*Air Inlet Thread Size: BSP or NPT 1/4".

Corner Attachment (Angle Head)

The Corner Attachment CA-14A can be mounted on straight or pistol grip type impact wrenches FW-14PX, 14SX to access fastening in confined spaces.



CA-14A

IMPACT WRENCHES+CORNER ATTACHMENT



CA-14A + FW-14SX-5

Model	Side to Center		Square Drive Size		Angle Head Height		Overall Length		Weight (without socket)		Models
	mm	in	mm	in	mm	in	mm	in	kg	lb	
CA-14A	24.5	31/32	12.7	1/2	84	3 5/16	146	5 3/4	1.4	3.0	FW-14PX,14SX Series

Impact Wrenches

Medium Size Straight Models

19mm (3/4")~31.8mm (1 1/4")



FW-19Z-5



FW-250-1,2



FW-320-1



FW-420-1C,2C



FW-320-1CL
(Long Anvil Type)
Inside Lever type



FW-420-1CL
(Long Anvil Type)
Inside Lever type

Model	Bolt Size	Recommended Torque Range			Max. Torque	Free Speed	Square Drive Size		Overall Length (without socket)		Weight (without socket)		Air Consumption (at Load)		Air Inlet Thread Size	Air Hose Size	
		N · m	kgf · m	ft · lb			N · m	min ⁻¹	mm	in	mm	in	kg	lb		m ³ /min	ft ³ /min
FW-19Z-5C	M18	235~450	24.0~45.9	173.3~331.9	560	5,000	19.0	3/4	322	12 43/64	5.2	11.5	0.6	21.2	3/8	9.5	3/8
FW-250-1C	M24	380~1040	38.8~106.1	280.3~767.0	1200	5,000	25.4	1	302	11 57/64	6.0	13.2	0.7	24.7	1/2	12.7	1/2
FW-250-2C	M24	380~1040	38.8~106.1	280.3~767.0	1200	5,000	19.0	3/4	302	11 57/64	6.0	13.2	0.7	24.7	1/2	12.7	1/2
FW-320-1C	M30~M33	600~1800	61.2~183.6	442.5~1327.5	2300	4,800	25.4	1	353	13 29/32	8.7	19.2	1.0	35.3	1/2	12.7	1/2
FW-320-1CL	M30~M33	600~1800	61.2~183.6	442.5~1327.5	2300	4,800	25.4	1	484	19 1/16	10.0	22.0	1.0	35.3	1/2	12.7	1/2
FW-420-1C	M36~M42	900~2500	91.8~255.0	663.8~1843.8	2800	4,500	25.4	1	349	13 3/7	10.8	23.8	1.2	42.4	1/2	19.0	3/4
FW-420-1CL	M36~M42	900~2500	91.8~255.0	663.8~1843.8	2800	4,500	25.4	1	501	19 3/4	12.5	27.5	1.2	42.4	1/2	19.0	3/4
FW-420-2C	M36~M42	900~2500	91.8~255.0	663.8~1843.8	2800	4,500	31.8	1 1/4	351	13 13/16	10.8	23.8	1.2	42.4	1/2	19.0	3/4

*Marked • are long anvil types. *Models with C are Inside Lever types.
*FW-19Z-5 is single clutch type. Other Models are 2-Jaw clutch types.

Medium Size Pistol Grip Models

19mm (3/4")~25.4mm (1")



FW-19PX-5



FW-250P-1,2



FW-320P-1

Model	Bolt Size	Recommended Torque Range			Max. Torque	Free Speed	Square Drive Size		Overall Length (without socket)		Weight (without socket)		Air Consumption (at Load)		Air Inlet Thread Size	Air Hose Size	
		mm	N · m	kgf · m			ft · lb	N · m	min ⁻¹	mm	in	mm	in	kg		lb	m ³ /min
FW-19PX-5	M18	235~450	24.0~45.9	173.3~331.9	560	5,000	19.0	3/4	239	9 13/32	4.4	9.7	0.6	21.2	1/4	9.5	3/8
FW-250P-1	M24	380~1040	38.8~106.1	280.3~767.0	1200	5,000	25.4	1	228	8 31/32	5.3	11.7	0.7	24.7	3/8	12.7	1/2
FW-250P-2	M24	380~1040	38.8~106.1	280.3~767.0	1200	5,000	19.0	3/4	228	8 31/32	5.3	11.7	0.7	24.7	3/8	12.7	1/2
FW-320P-1	M30~M33	600~1800	61.2~183.6	442.5~1327.5	2300	4,800	25.4	1	268	10 36/64	8.0	17.6	1.0	35.3	3/8	12.7	1/2

*FW-19PX-5 is single clutch type. Other Models are 2-Jaw clutch types.

Heavy Duty Straight Models

38.1mm (1 1/2")~63.5mm (2 1/2")

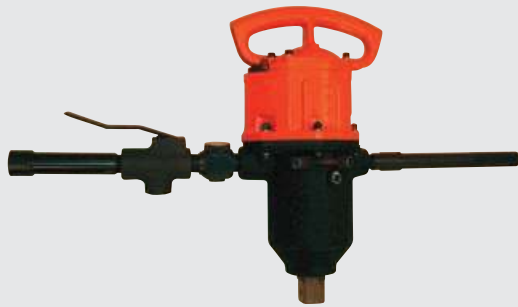

FW-50-7, 75-7



FW-100-1

Model	Bolt Size	Recommended Torque Range			Max. Torque	Free Speed	Square Drive Size		Overall Length (without socket)		Weight (without socket)		Air Consumption (at Load)		Air Inlet Thread Size	Air Hose Size	
		mm	N · m	kgf · m			ft · lb	N · m	min ⁻¹	mm	in	mm	in	kg		lb	m ³ /min
FW-50-7	M50	3300~7050	336.6~719.1	2433.8~5199.4	8400	4,000	38.1	1 1/2	500	19 11/16	33.0	72.6	1.9	67.3	1	19.0	3/4
FW-75-7	M68	5100~12400	520.2~1264.8	3761.3~9145.0	14000	3,000	63.5	2 1/2	610	24 1/64	60.0	132.0	2.1	74.9	1	19.0	3/4
FW-100-1	M76	9250~20800	943.5~2121.6	6821.9~15340.0	22000	2,500	63.5	2 1/2	700	27 9/16	85.0	188.7	3.2	114.1	1	25.4	1

*All Models are double clutch types.

Screwdrivers

Fuji screwdrivers are suitable for a wide range of screw fastening and disassembly applications. The compact and lightweight design provides operator comfort. All models are reversible via a reverse lever or push button. Impact clutch type models are all of double clutch design and their high torque and fast run-down minimise operator fatigue. Slip clutch type models are suitable for sheet metal screws and the torque setting can be adjusted easily.

IMPACT CLUTCH TYPE - Straight Models



FW-5SXD-7(70)



FW-5SXD-8(80)



FW-6SXD-6(60)

Model	Bolt Size	Recommended Torque Range			Max. Torque	Free Speed	Bit Shank Size		Overall Length (without socket)		Weight (without socket)		Air Consumption (at Load)		Air Hose Size	
		N · m	kgf · m	ft · lb			N · m	min ⁻¹	mm	in	mm	in	kg	lb	m ³ /min	ft ³ /min
FW-5SXD-7	M5	6~11	0.6~1.1	4.4~8.1	20	12,000	6.35	1/4	223	8 25/32	0.70	1.5	0.20	7.1	6.3	1/4
FW-5SXD-70	M5	6~11	0.6~1.1	4.4~8.1	20	12,000	6.35	1/4	223	8 25/32	0.70	1.5	0.20	7.1	6.3	1/4
FW-5SXD-8	M5	6~11	0.6~1.1	4.4~8.1	20	12,000	6.35	1/4	193	7 19/32	0.65	1.4	0.20	7.1	6.3	1/4
FW-5SXD-80	M5	6~11	0.6~1.1	4.4~8.1	20	12,000	6.35	1/4	193	7 19/32	0.65	1.4	0.20	7.1	6.3	1/4
FW-6SXD-6	M6	10~18	1.0~1.8	7.4~13.3	25	10,000	6.35	1/4	235	9 1/4	1.10	2.4	0.30	10.6	9.5	3/8
FW-6SXD-60	M6	10~18	1.0~1.8	7.4~13.3	25	10,000	6.35	1/4	235	9 1/4	1.10	2.4	0.30	10.6	9.5	3/8

*Air Inlet Thread Size: BSP or NPT 1/4".

Pistol Grip Models



FW-5PXD-6(60)



FW-6PLD-1



FW-6PXD-6(60)



FW-6PHD-1



FW-6PMD-1(10)

Model	Bolt Size	Recommended Torque Range			Max. Torque	Free Speed	Bit Shank Size		Overall Length (without socket)		Weight (without socket)		Air Consumption (at Load)		Air Hose Size	
		N · m	kgf · m	ft · lb			N · m	min ⁻¹	mm	in	mm	in	kg	lb	m ³ /min	ft ³ /min
FW-5PXD-6	M5	6~11	0.6~1.1	4.4~8.1	20	12,000	6.35	1/4	160	6 19/64	0.80	1.8	0.30	10.6	6.3	1/4
FW-5PXD-60	M5	6~11	0.6~1.1	4.4~8.1	20	12,000	6.35	1/4	160	6 19/64	0.80	1.8	0.30	10.6	6.3	1/4
FW-6PMD-1	M6	11~22	1.1~2.2	8.1~16.2	34	8,500	6.35	1/4	146	5 3/4	0.92	2.0	0.53	18.7	9.5	3/8
FW-6PMD-10	M6	11~22	1.1~2.2	8.1~16.2	34	8,500	6.35	1/4	146	5 3/4	0.92	2.0	0.53	18.7	9.5	3/8
FW-6PLD-1	M6	11~22	1.1~2.2	8.1~16.2	34	10,000	6.35	1/4	182	7 11/64	0.90	2.0	0.20	7.1	9.5	3/8
FW-6PXD-6	M6	10~18	1.0~1.8	7.4~13.3	25	10,000	6.35	1/4	168	6 5/8	1.20	2.6	0.28	9.9	9.5	3/8
FW-6PXD-60	M6	10~18	1.0~1.8	7.4~13.3	25	10,000	6.35	1/4	168	6 5/8	1.20	2.6	0.28	9.9	9.5	3/8
FW-6PHD-1	M8	19~40	1.9~4.1	14.0~29.5	60	9,000	6.35	1/4	154	6 1/6	1.35	3.0	0.35	12.4	9.5	3/8

*Air Inlet Thread Size: BSP or NPT 1/4".

Bit Size		FW-*SXD-6, 7, 8, *PXD-6, *P*D-1 A:9.5mm B:12mm
		FW-*SXD-60, 70, 80, *PXD-60, *P*D-10 A:13mm B:16mm

IMPACT CLUTCH TYPE



FW-44SAD~66SAD



FW-44PAD~66PAD

Model	Bolt Size	Recommended Torque Range			Max. Torque	Free Speed	Bit Shank Size		Overall Length (without socket)		Weight (without socket)		Air Consumption (at Load)		Air Hose Size	
		mm	N · m	kgf · m			ft · lb	N · m	min ⁻¹	mm	in	mm	in	kg	lb	m ³ /min
Straight Models																
•FW-44SAD-1	M5	6~13	0.6~1.3	4.4~9.6	20	5,700	6.35	1/4	207	8 5/32	0.66	1.4	0.35	12.4	6.3	1/4
•FW-44SAD-10	M5	6~13	0.6~1.3	4.4~9.6	20	5,700	6.35	1/4	207	8 5/32	0.66	1.4	0.35	12.4	6.3	1/4
•FW-66SAD-1	M6	11~20	1.1~2.0	8.1~14.8	28	5,000	6.35	1/4	218	8 19/32	0.78	1.7	0.37	13.1	6.3	1/4
•FW-66SAD-10	M6	11~20	1.1~2.0	8.1~14.8	28	5,000	6.35	1/4	218	8 19/32	0.78	1.7	0.37	13.1	6.3	1/4
Pistol Grip Models																
•FW-44PAD-2	M5	6~13	0.6~1.3	4.4~9.6	20	6,500	6.35	1/4	132	5 3/16	0.78	1.7	0.60	21.2	6.3	1/4
•FW-44PAD-20	M5	6~13	0.6~1.3	4.4~9.6	20	6,500	6.35	1/4	132	5 3/16	0.78	1.7	0.60	21.2	6.3	1/4
•FW-66PAD-2	M6	11~20	1.1~2.0	8.1~14.8	28	5,000	6.35	1/4	143	5 5/8	0.88	1.9	0.48	16.9	6.3	1/4
•FW-66PAD-20	M6	11~20	1.1~2.0	8.1~14.8	28	5,000	6.35	1/4	143	5 5/8	0.88	1.9	0.48	16.9	6.3	1/4

*Marked • are oil bath types.
*Air Inlet Thread Size: BSP or NPT 1/4".

SLIP CLUTCH TYPE



FD-4
FD-5



FD-4P
FD-5P

Model	Bolt Size	Recommended Torque Range			Free Speed	Bit Shank Size		Overall Length (without socket)		Weight (without socket)		Air Consumption (at Load)	
		mm	N · m	kgf · m		ft · lb	mm	in	mm	in	kg	lb	m ³ /min
Straight Models													
FD-4	M4	1~4	0.1~0.4	0.7~3.0	2,000	6.35	1/4	174	6 27/32	0.6	1.3	0.20	7.1
FD-5	M5	6~12	0.6~1.2	4.4~8.9	1,600	6.35	1/4	233	9 11/64	1.0	2.2	0.30	10.6
Pistol Grip Models													
FD-4P	M4	1~4	0.1~0.4	0.7~3.0	2,000	6.35	1/4	173	6 13/16	0.8	1.7	0.20	7.1
FD-5P	M5	6~12	0.6~1.2	4.4~8.9	1,600	6.35	1/4	216	8 1/2	1.2	2.6	0.30	10.6

*Air Inlet Thread Size: BSP or NPT 1/4".
*Air Hose Size: 6.3mm (1/4").

Bit Size		FW-***SD-1, **SAD-1, FD-4, 4P, 5, 5P FW-***PD-2, **PAD-2 A:9.5mm B:12mm
		FW-***SD-10, **SAD-10 FW-***PD-20, **PAD-20 A:13mm B:16mm

Open-end Wrenches

Fuji offers stall torque type Open-end Wrenches for fast, accurate tube nut tightening mainly used in the assembly of hydraulic and pneumatic brake pipes and other hose and cable connections in the car and aircraft assembly lines. Gear driven mechanism without ratcheting provides precise torque, low noise operation and long life service. One hand two-step mechanism simplifies the socket release back to the open position.



FOW-10-1



FOW-10-2

HEAD SIZE

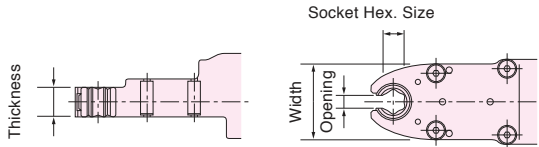

SOCKET SIZE

Model	Socket Hexagon Size (mm)	
	Standard	Other Sizes
FOW-10-1	10	8 • 9 • 3/8"
FOW-10-2	14	10 • 11 • 12 • 13 • 1/2"

*Specify the socket size in ordering the tool.

Model	Max. Torque			Free Speed	Head Size						Hex. Socket Size (Standard)	Overall Length		Weight		Air Consumption (at Load)		
	N • m	kgf • m	ft • lb		min ⁻¹	Thickness		Opening		Width		mm	in	kg	lb	m ³ /min	ft ³ /min	
FOW-10-1	13.6	1.4	10.0	410	14	35/64	6	15/64	36	1 27/64	10	25/64	294	11 37/64	1.5	3.3	0.4	14.1
FOW-10-2	18.5	1.9	13.6	300	14	35/64	9	23/64	40	1 37/64	14	35/64	306	12 3/64	1.6	3.5	0.4	14.1

*Air Inlet Thread Size: BSP or NPT 1/4". *Air Hose Size: 9.5mm (3/8").

Ratchet Wrenches

Ratchet Wrenches are used for fastening operations in confined spaces where angle impact tools and nutrunners cannot reach. Reverse operation can be accomplished by simply turning the wrench over.



FRW-6NX-3, -4(A)



FRW-8NX-2, (-2A)



FRW-10N-2



FRW-13N-3,-4

HEAD SIZE

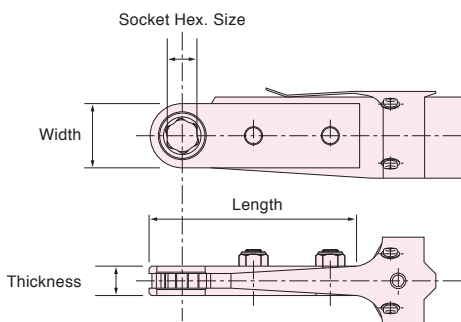

SOCKET SIZE

Model	Socket Hexagon Size (mm)	
	Standard	Other Sizes
FRW-6NX-3	10	8 • 8W • 10W
FRW-6NX-3A	10	8
FRW-6NX-4	13	12 • 12W • 13W
FRW-6NX-4A	13	12
FRW-8NX-2	14	10 • 12 • 13 • 1/2" • 9/16" • 10W • 12W • 13W • 14W
FRW-8NX-2A	14	10 • 12 • 13
FRW-10N-2	17	13 • 14 • 16 • 9/16" • 5/8" • 14W • 17W
FRW-13N-3	21	18 • 19 • 19W • 21W
FRW-13N-4	24	22 • 26 • 27 • 22W • 24W • 26W • 27W

*Specify the socket size in ordering the tool.

Model	Bolt Size	Max. Torque			Free Speed	Hex. Socket Size	Head Size						Overall Length		Weight		Air Consumption (at Load)	
		mm	N • m	kgf • m			ft • lb	min ⁻¹	mm	in	mm	in	mm	in	mm	in	kg	lb
FRW-6NX-3	M6	10.8	1.1	8.1	200	10	13	33/64	20	25/32	88	3 15/32	316	12 7/16	1.2	2.6	0.25	8.8
FRW-6NX-3A	M6	10.8	1.1	8.1	200	10	10	25/64	20	25/32	88	3 15/32	316	12 7/16	1.2	2.6	0.25	8.8
FRW-6NX-4	M6	12.7	1.3	9.4	170	13	13	33/64	24	61/64	93	3 21/32	320	12 9/16	1.2	2.6	0.25	8.8
FRW-6NX-4A	M6	12.7	1.3	9.4	170	13	10	25/64	24	61/64	93	3 21/32	320	12 9/16	1.2	2.6	0.25	8.8
FRW-8NX-2	M8	29.4	3.0	22.1	200	14	18	45/64	25	63/64	108	4 1/4	378	14 57/64	2.2	4.9	0.43	15.2
FRW-8NX-2A	M8	29.4	3.0	22.1	200	14	10	25/64	25	63/64	108	4 1/4	378	14 57/64	2.1	4.6	0.43	15.2
FRW-10N-2	M10	44.1	4.5	33.1	140	17	18	45/64	33	1 19/64	115	4 17/32	417	16 13/32	2.7	6.0	0.58	20.5
FRW-13N-3	M12	58.8	6.0	44.1	130	21	18	45/64	36	1 27/64	116	4 9/16	419	16 1/2	2.7	6.0	0.58	20.5
FRW-13N-4	M12	78.4	8.0	58.8	100	24	18	45/64	46	1 13/64	129	4 5/64	431	16 31/32	3.0	6.6	0.58	20.5

*Air Inlet Thread Size: BSP or NPT 1/4". *Air Hose Size: 9.5mm (3/8").

HEXAGONAL SOCKETS

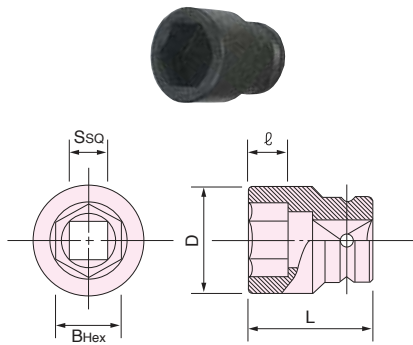

AC No.	Bolt Size		Size					Models	
	M	W	S (SQ) mm(in)	B (Hex) mm	L mm	l mm	D mm		
1101	4	-	9.53 (3/8)	7	20	4	13	FPT-110~770	
1102	5	-		8	25	5	13	FLT-4-1~5-1	
1103	6	1/4		10	25	7	16	FPW-110~770	
1104	7	-		11	25	7	18	FL-4-1~5-1	
1133	8	-		12	25	8	19	FW-5	
1105	8	-		13	27	8	20	FW-6, 44~66	
1106	-	5/16	14	27	8	22			
2101	6	1/4	12.7 (1/2)	10	35	7	18		
2118	8	-		12	35	8	21	FLT6-1~9-1	
2102	8	-		13	35	8	21	FL6-1~9-1	
2103	-	5/16		14	38	9	23	FW-6PH-11	
2104	10	3/8		17	38	10	27	FW-8	
2105	12	7/16		19	40	12	30	FW-88, 10, 14	
2106	-	1/2		21	40	14	33	except for FW-14PH-3	
2107	14	-		22	43	14	34		
4102	-	1/2		19.0 (3/4)	21	50	13	33	
4103	14	-			22	50	14	35	FPT-1660
4104	16	-	24		53	14	38	FPW-1660, 2220	
4105	-	5/8	26		53	15	40	FW-19	
4106	18	-	27		53	15	42	FW-2C	
4107	20	-	30		55	16	46	FW-250P-2	
4108	22	3/4	32		55	18	49		
5104	-	7/8	25.4 (1)		35	62	19	55	
5105	24	-		36	62	19	56		
5106	27	1		41	68	26	63		
5107	30	1-1/8		46	72	26	69	FW-1C	
5108	33	1-1/4		50	75	28	73	FW-250P-1	
5109	-	1-3/8		54	80	28	78	FW-320	
5110	36	-		55	80	28	80	FW-420	
5111	-	1-1/2		58	80	31	83		
5112	39	-		60	80	32	86		
6105	36	-		31.8 (1 1/4)	55	82	27	83	
6106	-	1-1/2	58		85	28	87	FW-420-2, 2C	
6107	39	-	60		88	30	89		
7107	-	1-5/8	38.1 (1 1/2)	63	100	30	96		
7108	42	-		65	100	32	98		
7109	-	1-3/4		67	100	33	101		
7110	45	-		70	100	34	104	FW-50-7	
7112	48	-		75	105	36	109		
7113	-	2		77	105	38	112		
8110	-	2	63.5 (2 1/2)	77	128	38	122		
8112	56	2-1/4		85	132	43	130		
8114	64	2-1/2		95	140	49	145		
8115	68	-		100	152	52	150	FW-75-7	
8116	72	-		105	154	54	168	FW-100-1	
8117	-	3		110	160	60	168		
8120	90	3-1/2		130	170	70	192		
8122	100	4		145	180	79	213		

*Other socket sizes are available on request.

EXTENSION BARS

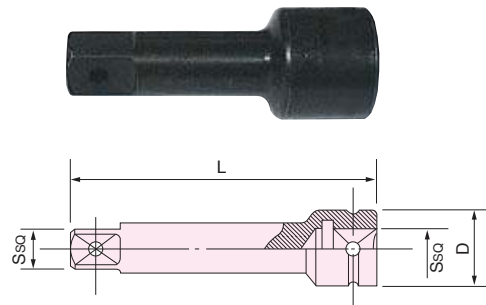

AC No.	Size			Models
	S (SQ) mm(in)	L mm	D mm	
1201	9.53 (3/8)	50	19	FPT-110~770
1202		75		FLT-4-1~5-1
1203		100		FL-4-1~5-1
1204		150		FPW-110~770
2201	12.7 (1/2)	50	25	FW-5, 6, 44~66
2202		75		FLT6-1~9-1
2203		100		FL6-1~9-1
2204		150		FW-6PH-11, 8, 88
4201	19.0 (3/4)	75	37	FW-10, 14 except for FW-14PH-3
4202		100		FPT-1660, FPW-1660, 2220
4203		150		FW-19
4204		200		FW-2C
5201	25.4 (1)	100	49	FW-250P-2
5202		160		FW-1C
5203		200		FW-250P-1
5204		300		FW-320
6201	31.8 (1 1/4)	150	62	FW-420
6202		200		
6203		250		FW-2C
6204		300		
7204	38.1 (1 1/2)	200	69	
7201		300		FW-50-7
8201	63.5 (2 1/2)	300	130	
8202		457		FW-75-7
				FW-100-1

UNIVERSAL JOINTS

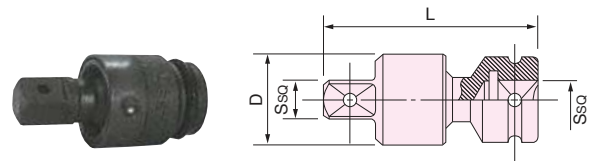

AC No.	Size			Models
	S (SQ) mm(in)	L mm	D mm	
1501	9.53(3/8)	48	24	FLT-4-1~9-1
				FPT-110
2502	12.7(1/2)	68	32	FL-4-1~9-1
				FPW-110
4502	19.0(3/4)	112	52	FW-5, 6, 44~66
				FW-11-1-20S-1-FL11-1-13-1
5502	25.4(1)	128	61	FW-6PH-11, 8, 88
				FW-10, 14 except for FW-14PH-3
6502	31.8(1 1/4)	151	74	FPT-1660, FPW-1660, 2220
7503				38.1(1 1/2)
				FW-250P-2
				FW-250~420
				FW-2C
				FW-50-7

Accessories

BITS SELECTION GUIDE

Fuji offers two types of screwdriver bits according to their neck length. Select suitable models or bits using the following table. Our screwdriver bits are available in three different categories of hardness to cover almost all applications: H (hard), G (standard), E (soft). The most common hardness bit are listed. Other hardness's are available on request.

GROUP	MODELS
(1)	FPT-110D-10, FLT-4D-1~4D-10~5D-1~5D-10~6D-1~6D10, 110SD-10, 330SD-10, 440SD-10, 550SD-10, 660SD-10 FPW-110D-10, 770D-30 - FL-4D-10~5D-10~6D-10, 110SD-10, 330SD-10, 440SD-10, 550SD-10, 660SD-10 FW-5SXD-70, 80, 6SXD-60, 5PXD-60, 6PMD-10, 6PLD-10, 6PXD-60, 6PHD-10, 44SAD-10, 66SAD-10, 44PAD-20, 66PAD-20
(2)	FPT-110D-1, FLT-4D-1~4D-10~5D-1~5D-10~6D-1~6D10, 110SD-1, 330SD-1, 440SD-1, 550SD-1, 660SD-1 FPW-110D-1, 770D-3 - FL-4D-1~5D-1~6D-1, 110SD-1, 330SD-1, 440SD-1, 550SD-1, 660SD-1 FW-5SXD-7, 8, 6SXD-6, 5PXD-6, 6PMD-1, 6PLD-1, 6PXD-6, 6PHD-1, 44SAD-1, 66SAD-1, 44PAD-2, 66PAD-2, FD-4, 5, 4P, 5P

SLOTTED BITS

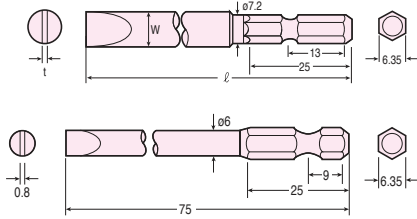

Thickness mm	Width mm	Length mm	Hardness	AC No.	Model Group
0.8	6	45	G	A166045	(1)
0.8	6	70	G	A166070	(1)
1.0	8	45	G	A168045	(1)
1.0	8	70	G	A168070	(1)
1.2	10	52	G	A161052	(1)
1.2	10	70	G	A161070	(1)
0.8	6	75	E	B356075	(2)

*Minimum order required : 100pcs. /item.

CROSS RECESSED BITS SINGLE-ENDED

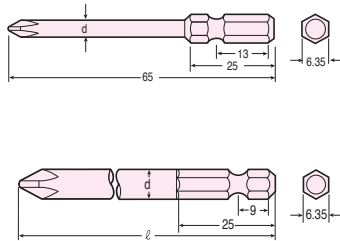

Diameter mm	Point Size	Length mm	Hardness	AC No.	Model Group
3	1	65	H	A161065	(1)
4.5	2	65	H	A162065	(1)
7	1	50	H	B351050	(2)
7	1	75	H	B351075	(2)
4.5	1	100	H	B351100	(2)
7	2	50	G	B352050	(2)
7	2	75	G	B352075	(2)
7	2	100	G	B352100	(2)
7	2	150	G	B352150	(2)
4.5	2	100	H	B252100	(2)
7	3	75	E	B353075	(2)
7	3	100	E	B353100	(2)
7	3	150	G	B353150	(2)

*Minimum order required : 100pcs. /item.

CROSS RECESSED BITS DOUBLE-ENDED

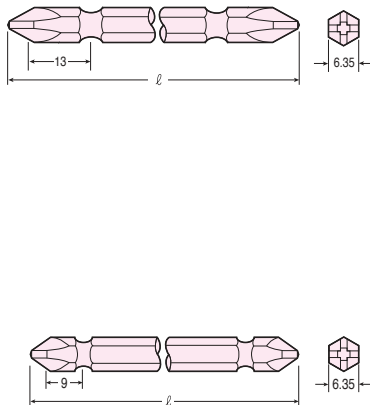

Point Size	Length mm	Hardness	AC No.	Model Group
1	45	H	A141045	(1)
1	65	H	A141065	(1)
1	110	H	A141110	(1)
2	45	G	A142045	(1)
2	65	G	A142065	(1)
2	110	G	A142110	(1)
2	150	G	A142150	(1)
2	200	G	A142200	(1)
2	300	G	A142300	(1)
3	45	E	A143045	(1)
3	65	E	A143065	(1)
3	110	E	A143110	(1)
1	75	H	B431075	(2)
2	50	H	B432050	(2)
2	75	G	B432075	(2)
2	100	G	B432100	(2)
2	150	G	B432150	(2)
2	200	G	B432200	(2)
3	75	E	B433075	(2)
3	100	E	B433100	(2)

*Minimum order required : 100pcs. /item.

CROSS RECESSED BITS DOUBLE-ENDED TORSION TYPE

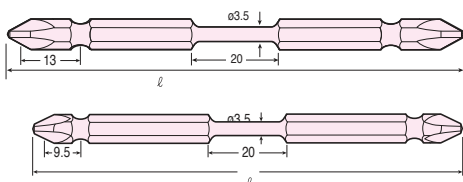

Diameter mm	Point Size	Length mm	Hardness	AC No.	Model Group
3.5	2	65	H	AT142065	(1)
3.5	2	110	H	AT142110	(1)
3.5	2	75	H	BT432075	(2)
3.5	2	100	H	BT432100	(2)

*Minimum order required : 100pcs. /item.

ALLEN BITS

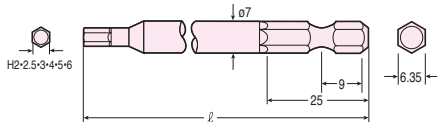
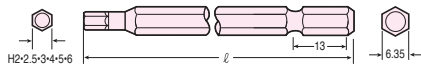

Hex Size mm	Length mm	Hardness	AC No.	Model Group
2	65	H	A16H2065	(1)
2	110	H	A16H2110	(1)
2.5	65	H	A16H25065	(1)
2.5	110	H	A16H25110	(1)
3	65	H	A16H3065	(1)
3	110	H	A16H3110	(1)
4	65	H	A16H4065	(1)
4	110	H	A16H4110	(1)
5	65	G	A16H5065	(1)
5	110	G	A16H5110	(1)
6	65	G	A16H6065	(1)
6	110	G	A16H6110	(1)
2	75	H	B35H2075	(2)
2	100	H	B35H2100	(2)
2.5	75	H	B35H25075	(2)
2.5	100	H	B35H25100	(2)
3	75	H	B35H3075	(2)
3	100	H	B35H3100	(2)
4	75	H	B35H4075	(2)
4	100	H	B35H4100	(2)
5	75	G	B35H5075	(2)
5	100	G	B35H5100	(2)
6	75	G	B35H6075	(2)
6	100	G	B35H6100	(2)

*Minimum order required : 100pcs./item.

TORX® BITS

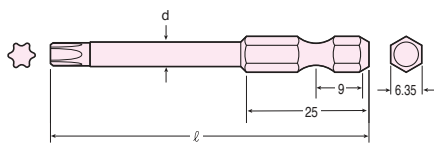
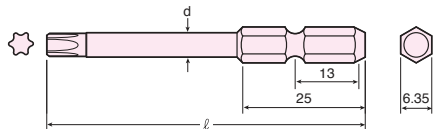

Point Size	Length mm	Body Diameter mm	AC No.	Model Group
T6	65	4.0	VT6065	(1)
T8	65	4.5	VT8065	(1)
T8	110	4.5	VT8110	(1)
T10	65	4.5	VT10065	(1)
T10	110	4.5	VT10110	(1)
T15	65	4.5	VT15065	(1)
T15	110	4.5	VT15110	(1)
T20	65	5.0	VT20065	(1)
T20	110	5.0	VT20110	(1)
T25	65	5.0	VT25065	(1)
T25	110	5.0	VT25110	(1)
T27	65	5.5	VT27065	(1)
T27	110	5.5	VT27110	(1)
T30	65	6.0	VT30065	(1)
T30	110	6.0	VT30110	(1)
T40	65	H6.35	VT40065	(1)
T40	110	H6.35	VT40110	(1)
T6	75	4.0	JT6075	(2)
T6	100	4.0	JT6100	(2)
T8	75	4.5	JT8075	(2)
T8	100	4.5	JT8100	(2)
T10	75	4.5	JT10075	(2)
T10	100	4.5	JT10100	(2)
T15	75	4.5	JT15075	(2)
T15	100	4.5	JT15100	(2)
T20	75	5.0	JT20075	(2)
T20	100	5.0	JT20100	(2)
T25	75	5.0	JT25075	(2)
T25	100	5.0	JT25100	(2)
T27	75	5.5	JT27075	(2)
T27	100	5.5	JT27100	(2)
T30	75	6.0	JT30075	(2)
T30	100	6.0	JT30100	(2)
T40	75	7.0	JT40075	(2)
T40	100	7.0	JT40100	(2)
T45	75	8.0	JT45075	(2)
T45	100	8.0	JT45100	(2)

*Minimum order required : 100pcs./item.

*TORX® is a registered trademark of Camcar Div., Textron Inc., USA.

Accessories

SOCKET HEAD BITS

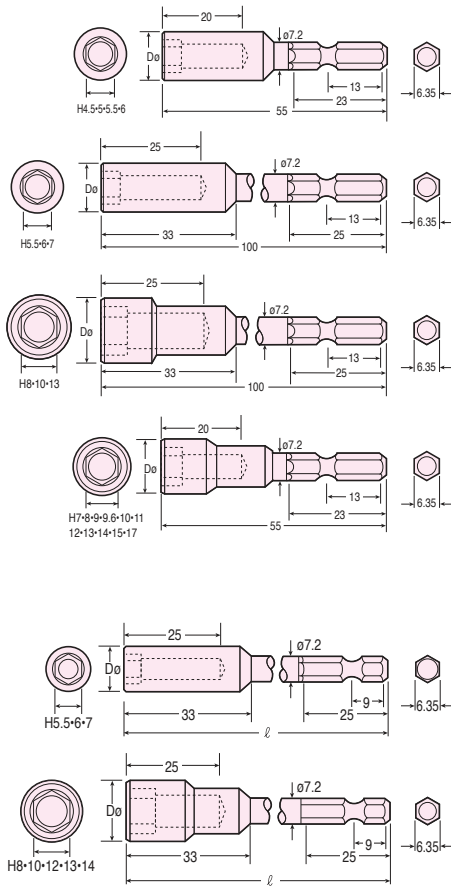

Hex Size	Length	Body Diameter	AC No.	Model Group
mm	mm	mm		
4.5	55	7.5	A2045055	(1)
5	55	8.5	A205055	(1)
5.5	55	10	A2055055	(1)
5.5	100	10	A2055100	(1)
6	55	10	A206055	(1)
6	100	10	A206100	(1)
7	55	13	A207055	(1)
7	100	13	A207100	(1)
8	55	13	A208055	(1)
8	100	13	A208100	(1)
9	55	16	A209055	(1)
10	55	16	A2010055	(1)
10	100	16	A2010100	(1)
11	55	16	A2011055	(1)
12	55	19	A2012055	(1)
12	100	19	A2012100	(1)
13	55	19	A2013055	(1)
13	100	19	A2013100	(1)
14	55	20	A2014055	(1)
15	55	22	A2015055	(1)
17	55	23	A2017055	(1)
5.5	75	10	B4555075	(2)
5.5	100	10	B4555100	(2)
6	100	10	B456100	(2)
7	75	13	B457075	(2)
7	100	13	B457100	(2)
8	75	13	B458075	(2)
8	100	13	B458100	(2)
8	150	13	B458150	(2)
10	75	16	B4510075	(2)
10	100	16	B4510100	(2)
10	150	16	B4510150	(2)
12	100	18	B4512100	(2)
13	75	19	B4513075	(2)
13	100	19	B4513100	(2)
14	100	20	B4514100	(2)

*Minimum order required : 100pcs./item.

ALLEN SOCKETS

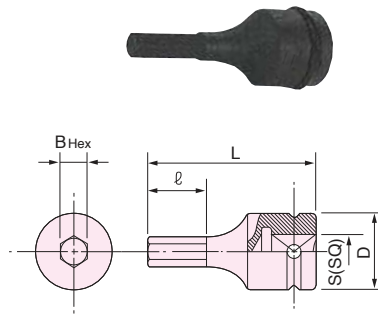

AC No.	Size					Models
	S (SQ)	B (Hex)	L	ℓ	D	
	mm(in)	mm	mm	mm	mm	
HG-3-4	9.53 (3/8)	4	50	15	19	FPT-110~770
HG-3-5		5	50	17	19	FLT-4-1~9-1
HG-3-6		6	50	18	19	FL-4-1~9-1
HG-3-8		8	60	23	20	FPW-110~770
HG-3-10		10	60	27	20	FW-5, 44~66
HG-4-6	12.7 (1/2)	6	60	18	25	FLT-11-1~20S-1
HG-4-8		8	60	23	25	FL-11-1~13-1
HG-4-10		10	68	27	27	FW-6PH-11, 8, 88
HG-4-12		12	68	30	27	FW-10, 14 except for FW-14PH-3
HG-4-14		14	78	40	28	

CHUCKS FOR WRENCHES FOR USE OF BITS

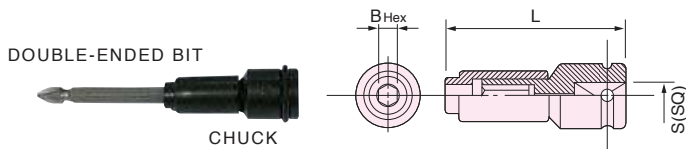

AC No.	Size			Models
	S (SQ)	B (Hex)	L	
	mm(in)	mm	mm	
DC-1	9.53(3/8)	6.35(1/4)	51	FPT-110, FLT-4-1~9-1 FPW-110, FL-4-1~9-1, FW-5, 6, 44~66
DC-2	12.7(1/4)	8.00(5/16)	56	FLT-11-1~20S-1 - FL11-1~13-1 FW-6PH-11, 8, 88, 10, 14 except for FW-14PH-3

TOOL COVER FOR FPW SERIES

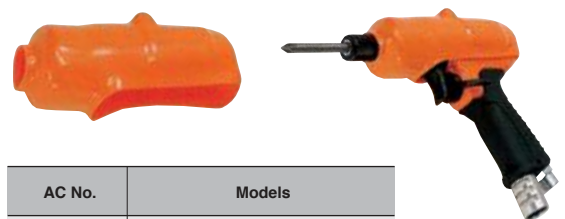

AC No.	Models
TCV-1	FL-5-1~6-1
TCV-2	FL-7-1