



Tightening automation.
Only excellent solutions.

**MCA: autofeed
tightening module**

Fiam®
PEOPLE AND SOLUTIONS

MCA: autofeed tightening module

MCA: the right solution to improve the productivity

A concentrate of innovation for a **faster productive process**: this is the autofeed tightening module MCA, **completely designed by Fiam**.

This innovative solution is equipped with:

- **Automatic screw feeding system (NCA)**
- **Fastening slide**
- **Air or electric nutrunner motor**

Thanks to the performances of these three components, the autofeed tightening module MCA is a must when **large and medium batches of the same screws have to be tightened**, when it has to be **integrated on pre-existing productive systems** and when it is necessary to optimize the times of the productive process. It is sufficient to introduce a manual start (for example pedal-key or start button) in order to obtain an independent semi-automatic tightening system.

It offers **concrete benefits** in productivity because:

- The screw is automatically sent from the bowl to the screw holding device
- The positioning and the tightening of the screw on the workpiece is automatic and accurate. Air or electric solutions can be chosen according to the tightening accuracy required (air shut-off torque control system or torque/angle control system)

High capacity vibrating bowl

for improved working autonomy; coated with anti-wear material



Soundproof transparent cover

for a better view of the inside without having to open the machine

PLC

manages all machine parameters depending on tightening needs

allows to connect the system to automatic air and electric solutions

integrates into automatic productive systems

manages input signals: tightening start, anomaly reset, emergency

gives output signals: anomaly, tightening result



Functional keypad

it adjusts easily and directly the machine parameters



Filter, regulator and lubricator group

with air pressure gauge, filters the inlet air and maintains constant the machine feed guaranteeing suitable tool lubrication



Optical fibre sensor

makes sure no screw gets stuck in the selection duct guaranteeing high and uninterrupted production



The screw is shot inside a closed chamber

which optimises screw speed and consequently the productive process optimizing the use of compressed air



Comfortable and rational hose

that includes the air and electric cables between slide and feeder

Pneumatic cylinders

equipped with built-in air decelerators

Fastening slide available in two versions:

- **with single movement:** it has only the movement of the motor
- **with dual movement:** with independent movements between head and motor

Motor:

Air nutrunner motor guarantees high torque accuracy
High technology electric nutrunner motor combined with the feed unit and the control unit guarantees maximum quality of the tightening process

Screw passage sensor

The selector

increases speed and productivity and guarantees unvaried calibrations in time



External structure

of small dimensions, which can be dismantled easily for maintenance



Be demanding

Reliability

A careful design guarantees long lifetime and reliability of the components which results in high productive process, less maintenance and repair costs

The screw feeder

The **PLC** (Programmable Logic Controller) permits

- high **process reliability**: the production cycle can be monitored and diagnosed as it can be interfaced with operator panels, LED, piece-counting devices, coloured lights
- **integrability into automated production systems**: since it can be interfaced with other "master" PLCs, it is easy to use with existing automatic processes

The **optical fibre sensor** makes sure no **screw gets stuck** in the selection duct guaranteeing high and uninterrupted production

The **selector** is **extremely reliable** even when the feeder is subject to logistic moves: in fact, the selector's calibration parameters do not change thanks to its more solid and compact design and screw device for accurate adjustment of the height

Feeding hoses which, keeping their original shape at all times, make screw passage easier and quicker with no chance of getting stuck

Fastening slide

Available in 2 versions

- **version 15 for air nutrunner motors**: optimizing spaces, they allow to place side by side two autofeed systems
- **version 20 for electric nutrunner motors**

Manufactured with **aluminium alloy**, it is so light that it can be used on solutions with manipulators (for example: electrical axis or anthropomorphic arms)

Nutrunner motors

- **Thanks to torque control system Jointech Plus** (with immediate and automatic air shut-off), **the air motors assure high torque repeatability, high performances and maximum reliability**; consequently the quality of the assembled product improves
- The **electric nutrunner motors** are connected to feed units (to supply correct feed parameters: voltage, current, etc...) and to control units which by a suitable programming, allow a **high torque repeatability** and reduced torque scattering

Don't be satisfied with the maximum

Productivity

Considerable increase of the efficiency of the productive cycle thanks to innovative systems

The screw feeder

The **PLC** (Programmable Logic Controller) permits to make **several adjustments**: bowl vibrating time, screw shooting time, parameters of optical fibre, min. tightening time to prevent false start, screw shooting delay time

The **selector** increases speed **considerably** and hence system **productivity** with a maximum capacity of 120 screws/minute

The **screw is shot inside a closed chamber** which **optimises screw speed considerably**: there is no longer any dissipation of compressed air and power is concentrated entirely on speeding up the screw's path. In turn, this speed quickens the whole system and optimizes the productivity process as a result

The **filter and lubrication group complete of air gauge** filters the air and maintains constant the machine feed guaranteeing suitable nutrunner motor lubrication

The whole feeding system has been standardised with **Festo components** for **greater reliability**

Fastening slides

These slides are **ideal** especially for **applications where the distance between the centre is close; thanks to their very compact size** (40 mm in width) they can be used in existing production systems

Upon request, slides having **different approaching strokes**, with depth control device with a precision with an interval having max. range of 0.5 mm

Slides housing the nutrunner motor are available:

- **with single - movement** (1 pneumatic cylinder): ideal solution when the approach stroke of the slide on the workpiece is made with manipulators, scara robot and anthropomorphic robot
- **with dual - movement** (2 pneumatic cylinders, one for motor stroke and the second for the head approaching stroke-in mm): ideal solution when the

approach stroke on the workpiece is being made by the slide

Nutrunner motors

The air nutrunner motors:

- **extremely versatile**, these motors can be used with nearly any type of joint
- They offer a very **wide range of rotation speeds** and tightening torque

The **electric nutrunner motors** guarantee considerable reduction of the productive times: **there is no need of post-process control as extremely accurate fastening is guaranteed**



Perfection is
in your hands

Ergonomics Ecology

Optimization of performances in regard to operator safety in working environments

The screw feeder

Volumes have been **reduced** for easy integration in the production areas and for **easy logistics management**

The **transparent cover is bigger** for a **better view** of the inside without having to open the machine

Materials used for improved **soundproofing** (upon request cover according to Norm IP 54 is available)

The layout of the **electro-pneumatic cables** permits to convey them in a pleated hose to guarantee a greater operator's safety

Fastening slide

Upon request a **carter for slide protection** in transparent polycarbonate for a good view of the inside and greater operator's safety is available

Nutrunner motors

The **air nutrunner motors**:

- Feature **extremely effective silencing systems** for muffling the noise generated by the air exhaust, and fully comply with all current International Standards
- Careful analysis of internal gears has also led to a **significant reduction in mechanical noise**
- The air nutrunner motors guarantee **great working safety** and thus give excellent performances on assembly equipment where they are used

The electric nutrunner motors meet the most important ergonomic requirements such as **low noise level** and **maximum safety** (thanks to the low electric voltage); so they guarantee comfortable working environments to the operators

Naturally
innovative

Innovative systems designed paying even more attention with respect to environment and of its safeguard

High reduction of electricity

consumption: the vibrator's special timed system stops the screw feed automatically when it is not required, thus **eliminating unnecessary electricity consumption**

The **screw is shot inside a closed chamber** which optimises the power of compressed air because there is **no longer dissipation**

The torque control system Jointech-Plus has a high running speed which, together with the push-to-start system, **reduces working time of the nutrunner motor and the compressed air consumption**

The electric nutrunner motors **safeguard the working environment** from the presence of environmental pollution caused by the oil exhaust of the compressed air

All the components are **easy to dispose** of because they are built using recyclable materials; therefore they do not represent any danger for environmental pollution

All Fiam products are supplied **eco-friendly packaging**



THE PLUS AS USUAL:

PRE-SALES AND AFTER-SALES SERVICE

The MCA system has been designed so that it can be adapted to any tightening situation. Thanks to its long experience in the most different situations concerning the automatic assembly and to its great flexibility in the designing and manufacturing systems, **FIAM expert technical staff is at customer disposal** to supply the best solution for every specific and special assembly requirement. Please contact directly Fiam or the local distributor to ask for an offer

Technical features of the autofeed tightening module MCA

Composed by automatic screw feeding system, air or electric nutrunner motor, fastening slide

	Type of nutrunner motor	Tightening torque on soft joint	Idle speed	Reversibility	Type of slide	Version	Max. tightening and approaching strokes
	Model	Nm	rp.m.	Type	Version	Type	mm
Air motor with Air shut-off Jointech Plus	MCZE 3A	0,8 ÷ 2,5	1300	↻	15	Single/Dual	80
	MCZE 4A	0,6 ÷ 3,5	900	↻	15	Single/Dual	80
	MCZE 5A	0,6 ÷ 5	550	↻	15	Single/Dual	80
	MCSEZ 4A	0,9 ÷ 4	2500	↻	15	Single/Dual	80
	MCSE 5A	2,5 ÷ 5	1500	↻	15	Single/Dual	80
	MCSE 8A	2,5 ÷ 8	1000	↻	15	Single/Dual	80
	MCSE 10A	2,5 ÷ 10	500	↻	15	Single/Dual	80
Air motor with Slip clutch Uni Jointech	MCZE 3	0,8 ÷ 3	1300	↻	15	Single/Dual	80
	MCZE 4	0,8 ÷ 3,3	850	↻	15	Single/Dual	80
	MCZE 5	0,6 ÷ 4,2	600	↻	15	Single/Dual	80
	MCSE 5	1,5 ÷ 7,5	1500	↻	15	Single/Dual	80
	MCSE 8	1,5 ÷ 9,5	1000	↻	15	Single/Dual	80
	MCSE 10	1,5 ÷ 12	500	↻	15	Single/Dual	80
Electric motors with indirect control	15MCB 05C1*	1 ÷ 5	1700	↻	20	Single/Dual	80
	15MCB 10C1*	2 ÷ 10	700	↻	20	Single/Dual	80
	15MCB 20C1*	4 ÷ 20	350	↻	20	Single/Dual	80
	17MCB 30C1*	6 ÷ 30	600	↻	20	Single/Dual	80
Electric motors with direct control	15MCB 05A1*	0,5 ÷ 5	1700	↻	20	Single/Dual	80
	15MCB 10A1*	1 ÷ 10	700	↻	20	Single/Dual	80
	15MCB 20A1*	2 ÷ 20	350	↻	20	Single/Dual	80
	17MCB 30A1*	3 ÷ 30	600	↻	20	Single/Dual	80

Legend

↻ Screw rotation clockwise

- The figures shown are measured at a pressure of 6,3 bar (ISO 2787), the recommended operating pressure.
- The tightening torque values have been measured in accordance with ISO 5393 standard.

Air nutrunner motors:

The torque values are to be considered purely indicative and may be influenced by the softness of the type of joint, the type and length of the screw, the pressure and quantity of the feeding air, etc. In order to ensure the best performances and long life of air nutrunner motors, in particularly harsh work conditions (high number of cycles per minute and/or high torque values), we advise using motors with a torque no more than 80% higher (indicative value) than the maximum indicated in the table.

Electric nutrunner motors:

Data shown in the table are indicative and can be changed without prior notice. Torque values are purely indicative and may be influenced by the softness of the type of joint, by the type and length of the screw, and by the type of accessory used.

For all further details, please apply to Fiam Technical Consultancy Service.

* High technology electric nutrunner motors

The electric nutrunner motors have to be connected to

- feed unit TOD...: used to feed the motor and supply correct feed parameters
- control unit TOC...: used to control and monitor the assembly cycle

Motors and units are connected to a kit of cables

For further information see catalogue "MCB: high technology electric nutrunner motors" (n. 71)

For further information about nutrunner motors see correspondent Fiam catalogue:

- n. 27 Air nutrunner motors with air shut-off clutch
- n. 28 Air nutrunner motors with slip clutch
- n. 71 MCB: high technology electric nutrunner motors)

Standard equipment (supplied with the system)	Accessories available upon request	Models available upon request
<ul style="list-style-type: none"> • Air nutrunner motors: <ul style="list-style-type: none"> - Clutch adjustment key - Supplementary clutch spring • Electric nutrunner motors <ul style="list-style-type: none"> - Feed unit - Control unit - Kit of cables - Test certificate • Fastening slide: <ul style="list-style-type: none"> It slides on ball recirculating runners, complete with magnetic cylinders and sensors for stroke limit, pneumatic decelerators, pneumatic fittings and supporting bracket • Screw passage sensor • Use and maintenance manual • Eco-friendly packaging 	<ul style="list-style-type: none"> • For electric solution: test/checking service of assembly system at the client's production lines directly • Carter for protection slide in polycarbonate • Support column (upon request, it can be customized according to the customer needs) • Depth sensor 	<ul style="list-style-type: none"> • Models with air nutrunner motors: without clutch with stall function • Fastening slide: <ul style="list-style-type: none"> - Models with different approaching strokes - Models with a device to control precision depth with a maximum range of 0.5 mm • Models with air and electric models with only left rotation • Models with air nutrunner motors to obtain higher torque range than what stated in the above chart

Dimensions

Automatic screw feeding system

Air connection:	1/4" F
Power features:	220 V/50 Hz - 110 V/60 Hz
Air consumption:	5 - 8 l/cycle
Sound pressure level:	<75 dB(A)
Diameter of the bowl:	ø 220 mm
Capacity of the bowl:	1 litre
Weight:	36 Kg
Connecting hose to the motor:	4 m

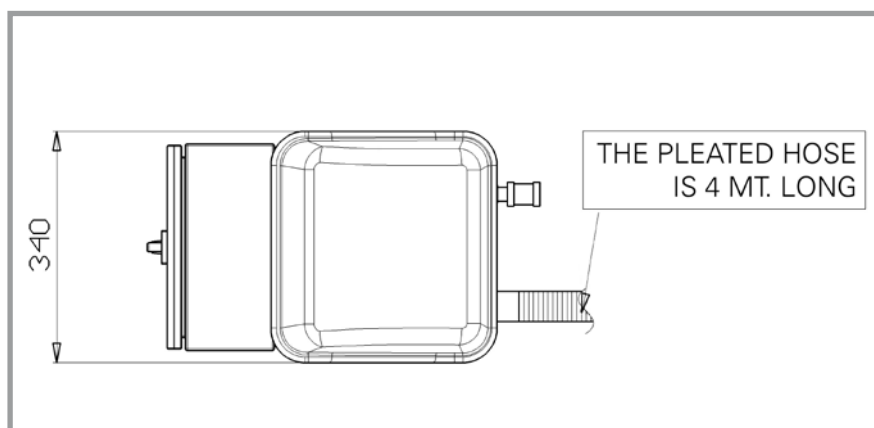
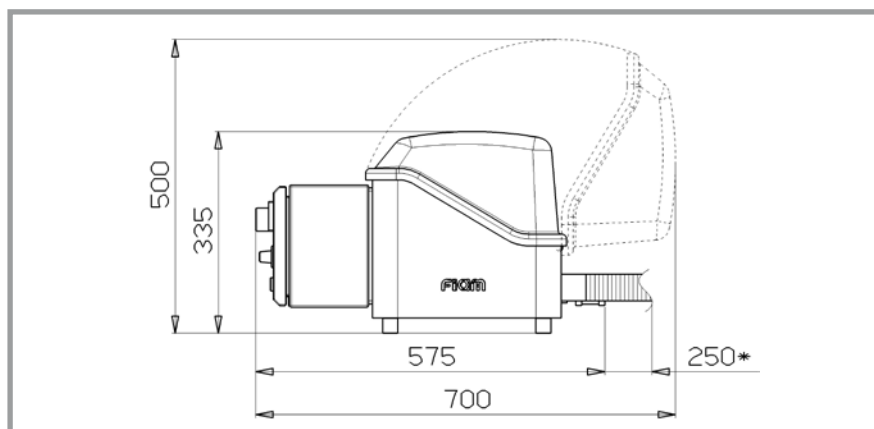

Dimensions

Fastening slide

Version 15 for air nutrunner motors

Single-movement

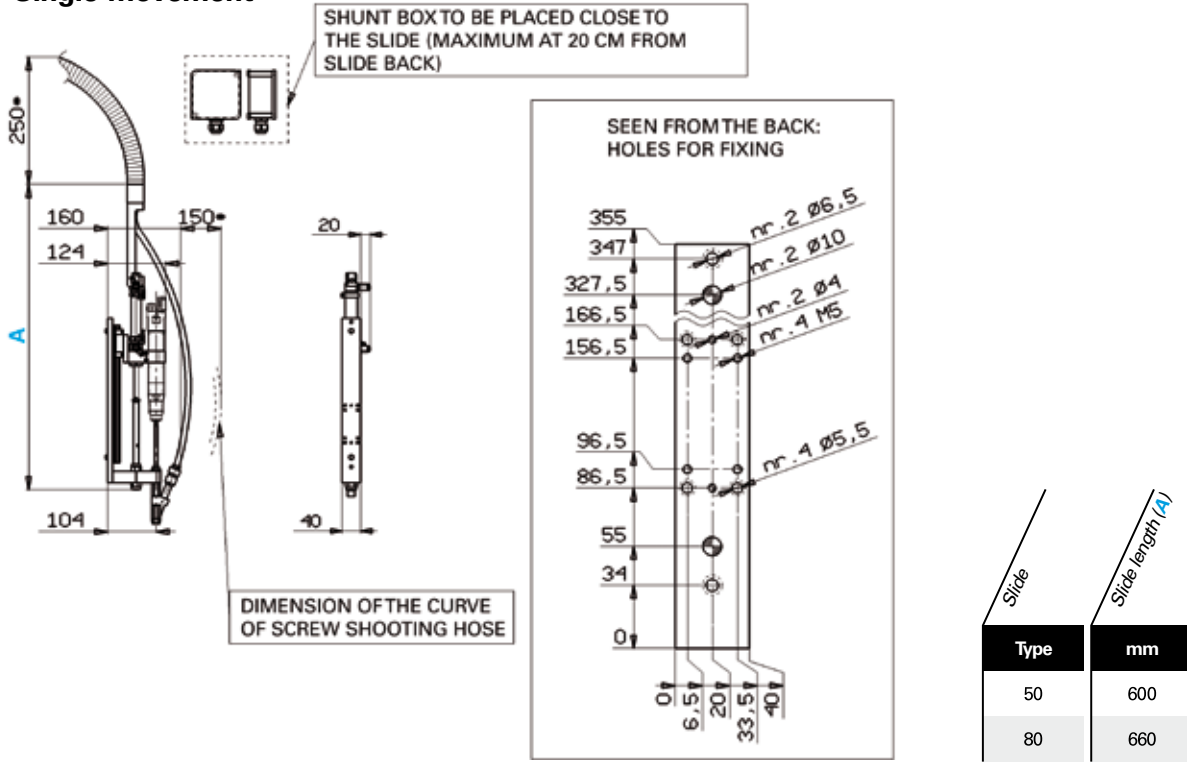

Dual-movement

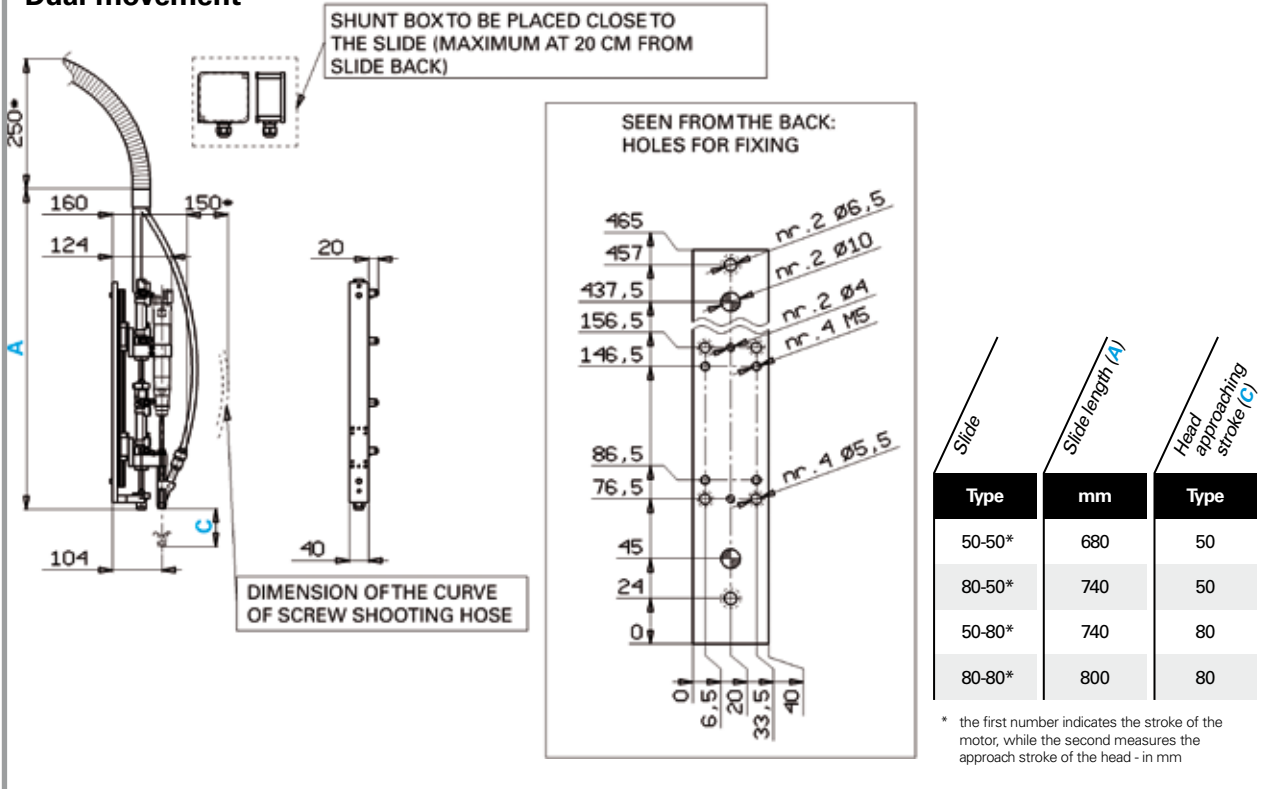

Dimensions

Fastening slide

Version 20 for electric nutrunner motors

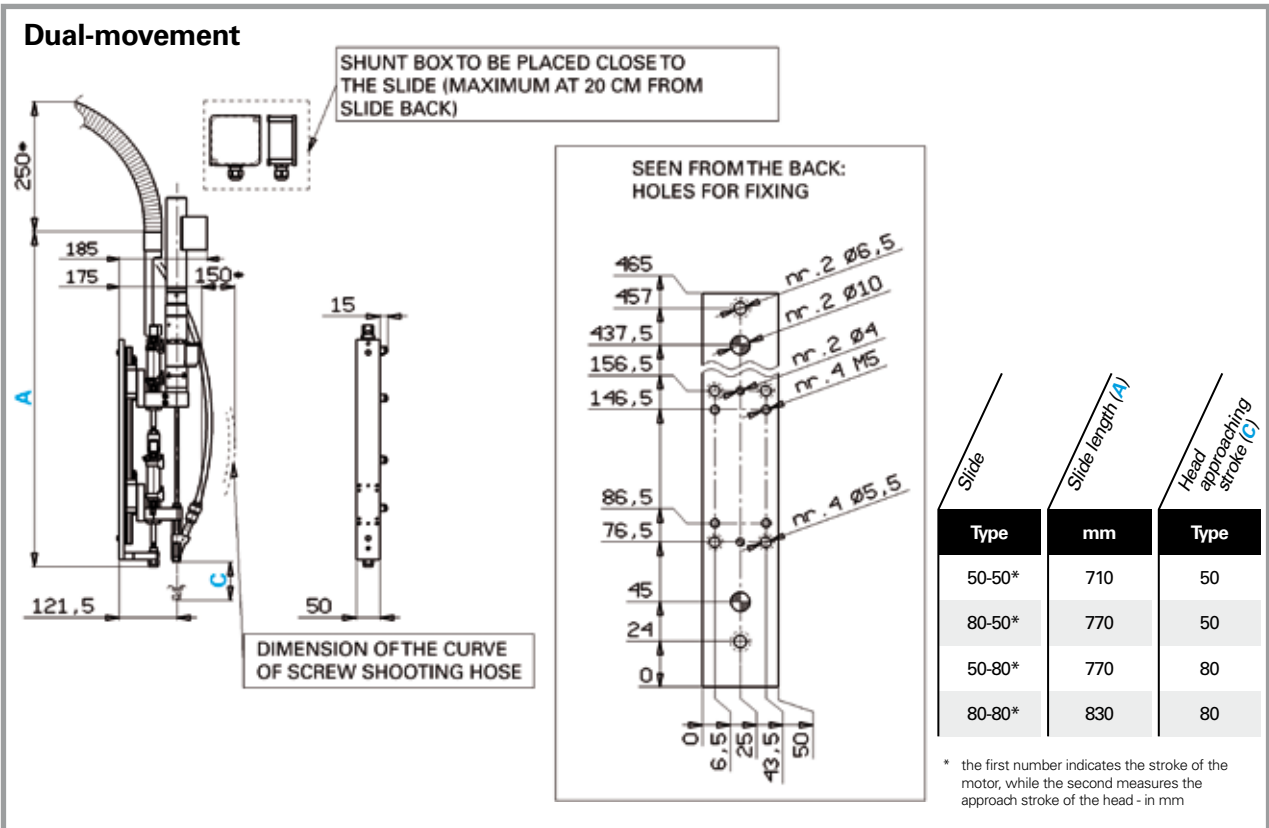
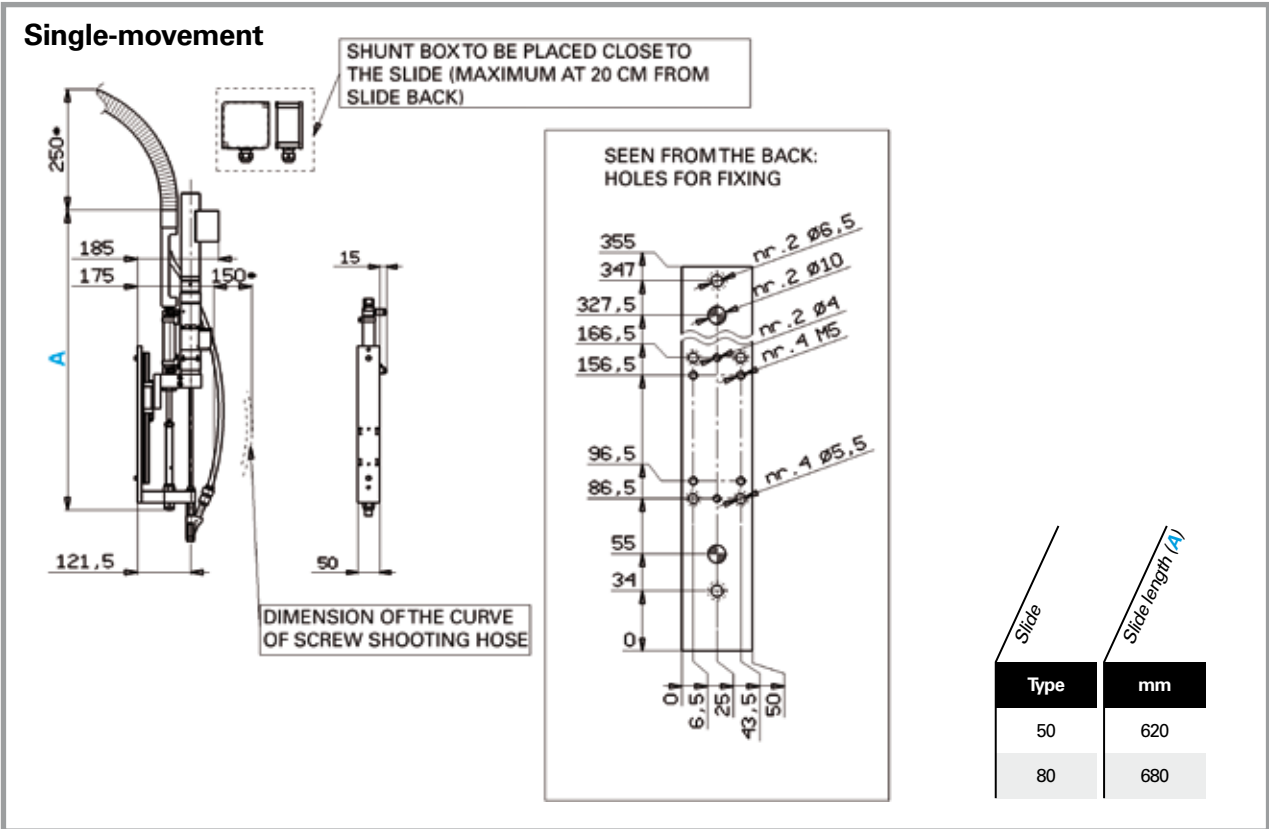

* the first number indicates the stroke of the motor, while the second measures the approach stroke of the head - in mm

- For the dimensions of feed and control units see catalogue "MCB: high technology electric nutrunner motors" (n. 71)

How to choose a autofeed tightening module MCA

To choose a autofeed tightening module MCA we have to consider:

- Material to tighten (plastic, wood, steel, etc.)
- Dimensions and encumbrance of component to assemble
- Tightening torque and speed

but **the most important is the screw.**

The autofeed tightening module MCA is able to tighten:

- **any screws** (metric, self-threading, self-tapping, self-drilling, three-lobe, etc.)
- **any type of head** (countersunk, flat, cylindrical, oval, etc.)
- **any type of imprint** (slotted, cross-slotted, torx, hex socket screw, hex head) and with knurled washer under the head too.

Screws samples are always required to formalize the order. For customized solutions, both screws and workpieces samples are required.

Dimensions of the head (D): $\varnothing 4,5 \div 10,5^*$ mm
Total length of the screw (h): from 8 up to 35 mm
Screws with hexagonal head: hexagon max 7mm

* For maxi heads the maximum length is 13,5 mm

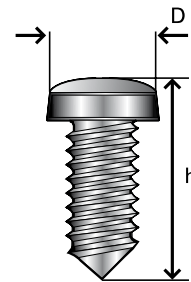

Total length of any screw must be minimum 1,5 times of the head diameter

Example: \varnothing head screw = 8 mm
Min h (high) = 12 mm (12 : 8 = 1,5)

EXAMPLE

Customer need:

To tighten in vertical position a plastic profile with self-threading screw. Plane surface without encumbrance. The approach stroke on the workpiece is made by the slide.

Type of motor: **MCSE5A**
 Slide movement: **dual (D)**
 Support column: **no**

Screw feature

- Flat countersunk heads
- Imprint: Phillips 2

Dimension of the screw

- Standard screw D = 6,9 mm
 H = 14 mm
 d = 3,9 mm

Tightening type

- Torque: 3Nm
- Accuracy: 10%
- Speed: 1500 rpm
- Material: plastic
- Cycle: Quantity of screws/ components: 1
 Autonomy: 2 Hours
- Type of tightening: from the top towards the bottom

Positioning of tightening

- Plane surface without obstruct

The autofeed tightening module is

MCA - D MCSE5A

autofeed tightening module

Slide with **D**ual movement
(S)lide with single-movement)

Type of motor

How to order a customized autofeed tightening module MCA

To receive in very short-time a customized offer, complete the following form and send it by fax +39 0444 385002
For information about the following form contact the **Fiam Technical Consultancy Service**.

Type of motor : _____

Slide movement : single (S) dual (D)

Support: yes no

Tightening and approaching strokes (if different from standard dimensions indicated on page 8-9): _____

Special models: _____

Screws features	
Heads	<input type="checkbox"/> Flat Countersunk <input type="checkbox"/> Cylindrical <input type="checkbox"/> Oval <input type="checkbox"/> Hexagonal <input type="checkbox"/> Oval Countersunk <input type="checkbox"/> Oval Cylindrical
	<input type="checkbox"/> Phillips <input type="checkbox"/> PoziDrive <input type="checkbox"/> Slotted <input type="checkbox"/> Hex Socket Screws <input type="checkbox"/> Torx <input type="checkbox"/> Hex <input type="checkbox"/> Other _____

Dimensions of the screw

Standard screw

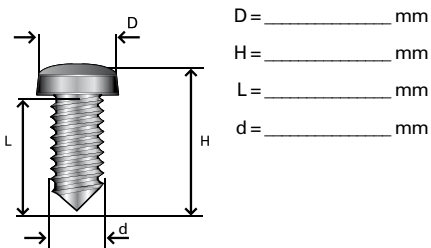

Knurled washer under the head

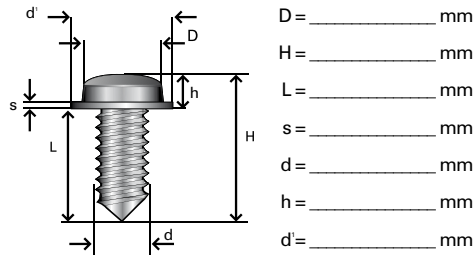

Tightening type

Torque : _____ Nm

Accuracy: _____ %

Speed: _____ Rpm

Materials:

- Wood
- Plastic
- Aluminium
- Steel
- Iron
- Other _____

Cycle

Quantity of screws/components _____

Nr. pieces/hour _____

Autonomy _____ Hours

Type of tightening

- Horizontal
- From bottom towards the top
- From the top towards the bottom
- Other: _____ Degrees

Position of tightening

Plane surface without obstruct

Near to wall

Embedded

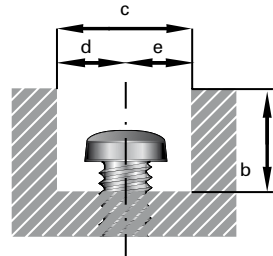
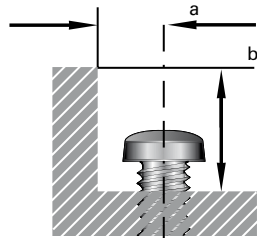

Dimensions (mm)

a = _____

b = _____

c = _____

d = _____

e = _____

Attached drawings of the piece

Other details

Particular solution in order to not damage the piece:

Length of the screw feed hose (4 mt supplied as a standard): other lenght

Feeding pressure in line:

Screws samples sent*:

Pieces samples sent:

**Without screws Fiam offers only an indicative feasibility.*

Compiled by _____

Company _____

no yes _____

no yes _____ mt.

220V, 50Hz other _____

no yes _____ quantity

no yes _____ quantity

Date _____

Tel. _____

Mail _____



Fiam Utensili Pneumatici Spa
Viale Crispi 123 - 36100 Vicenza - Italy
Tel. +39.0444.385000
Fax +39.0444.385002
customerservice@fiamairtools.com
www.fiamairtools.com

