



POWERTOOLS
HYDRAULICS

Cutters
RC, HPC



Cutters: The cutting edge of efficiency

Sometimes you need to cut very hard or tough materials. The really efficient, safe, and ergonomic method is to use a hydraulic cutting tool to get the job done quickly and easily.

Cutter HPC 7.2-40 is a simple solution for cutting, e.g., steel plate, rod, and electric cables. The square opening of the cutter is 40 x 40 mm, and the tool is very useful in many applications, especially where space is restricted.

Our rivet cutter RC 25-30 is, as its name suggests, specially designed to cut off rivet heads in, e.g., truck chassis and crash-barriers. The practical design also prevents the rivet heads from flying away.

Of course, we can adapt cutters for other types of job, such as those in which the cutters have to overlap.

- **Working pressure 800 bar**
- **Single-acting with spring return**
- **Works in restricted spaces**
- **Special designs on request**

Cutters
 RC, HPC



RC

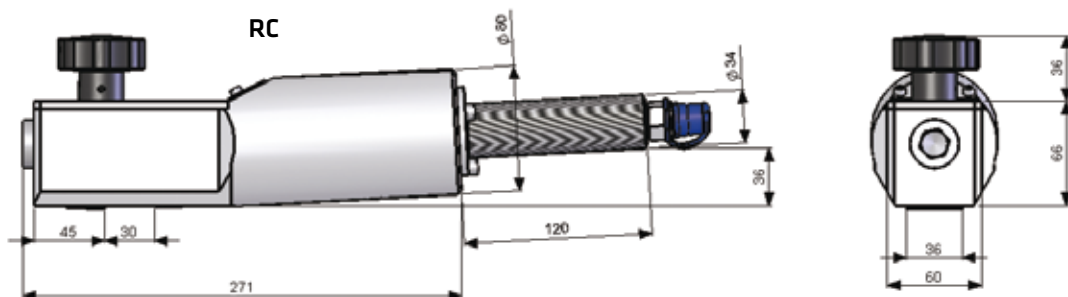

HPC

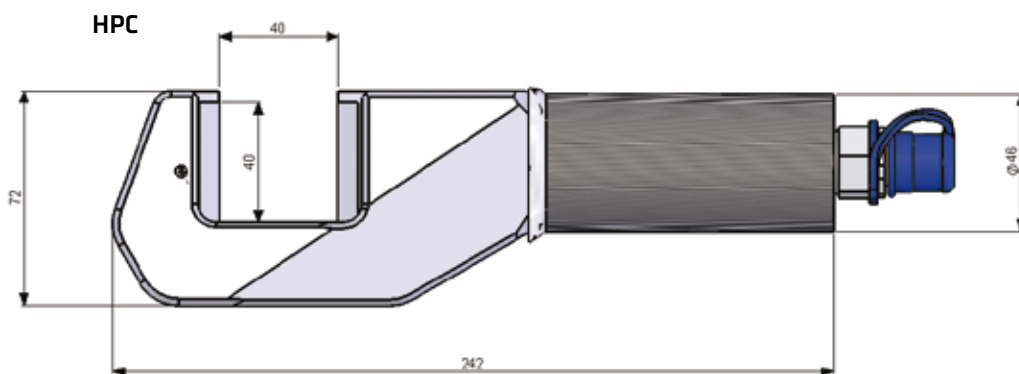

Cutters-RC,HPC

Article number	Capacity rivet head	Capacity rivet shaft	Cutting force	Working pressure	Oil volume	Weight
	ϕ mm	ϕ mm				
RC 25-30	30	16	25 / 244.6	800	94	9
HPC 7.2-40	-	-	7.2 / 71.3	800	36	3.7

* Rounded value, see kN for exact value