



POWERTOOLS
HYDRAULICS

Air driven
hydraulic pumps
PL, PLF



Air driven hydraulic pumps: The natural choice for the workshop environment

Because there is almost always a compressed-air system in workshops, this type of pump is especially applicable to that environment. It is also a very good alternative to hand pumps – not least in continual and demanding operations with single-acting cylinders. We offer two different variants of compressed-air driven hydraulic pumps.

Our PL series has a foot pedal, so you can work with both hands free while you operate the pump, which helps when you want to use a cutter, a cylinder, or some other tool that needs to be adjusted or set up.

If you choose a pump from the PLF series, it will have remote control, which means you can move away from the hydraulic pump to get a better view of the work progress.

- **Working pressure up to 800 bar**
- **Foot or remote control**
- **Low weight**
- **Special designs on request**



POWERTOOLS
HYDRAULICS

Air driven
hydraulic pumps
PL, PLF

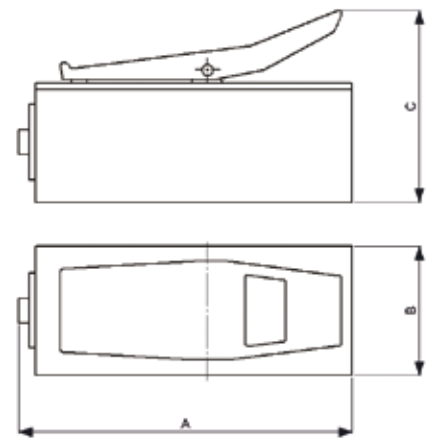

PL 48



PLF 18



PL 18

Air driven hydraulic pumps - PL, PLF

| Article number | Remote Control | Maximum working pressure | | Flow high pressure | Oil volume cm ³ | Sound Pressure dB (A) | Length | Width | Height | Weight Kg | | | |
|----------------|----------------|--------------------------|-----|--------------------|-------------------------------|--------------------------|--------|-------|--------|--------------|-----------------|---|---|
| | | MPa | Bar | l / min | | | | | | | Dimension in mm | | |
| | | | | | | | | | | | A | B | C |
| PL 125 | - | 25 | 250 | 2.1 | 1400 | 78 | 297 | 115 | 171 | 5.1 | | | |
| PL 17 | - | 70 | 700 | 0.8 | | | | | | | | | |
| PLF 17 | X | 70 | 700 | 0.8 | | | | | | | | | |
| PL 18 | - | 80 | 800 | 0.7 | | | | | | | | | |
| PLF 18 | X | 80 | 800 | 0.7 | 4500 | 75 | 420 | 198 | 221 | 14 | | | |
| PL 47 | - | 70 | 700 | 0.8 | | | | | | | | | |
| PLF 47 | X | 70 | 700 | 0.8 | | | | | | | | | |
| PL 48 | - | 80 | 800 | 0.7 | | | | | | | | | |
| PLF 48 | X | 80 | 800 | 0.7 | 6900 | 75 | 630 | 198 | 221 | 17 | | | |
| PL 77 | - | 70 | 700 | 0.8 | | | | | | | | | |
| PLF 77 | X | 70 | 700 | 0.8 | | | | | | | | | |
| PL 78 | - | 80 | 800 | 0.7 | | | | | | | | | |
| PLF 78 | X | 80 | 800 | 0.7 | | | | | | | | | |

For further information, please see our price list or browse www.powertools.se.